



Installing a Cisco 6015 with a POTS Splitter Configuration in a Commercial Environment

This chapter provides installation procedures for a Cisco 6015 with a POTS splitter configuration in a commercial environment.

Warning

Only trained and qualified personnel should be allowed to install, replace, or service this equipment.

Caution

Before you start the installation procedures, read the entire chapter for important information and safety warnings.

Note

Before installing and cabling the equipment, be aware of standard safety practices and the hazards involved in working with electrical circuitry to prevent accidents. See the [“Safety Requirements” section on page 2-1](#) for all cautions and warnings that are necessary to ensure a safe and hazard-free installation.

To see translations of the warnings that appear in this publication, refer to the *Regulatory Compliance and Safety Information for the Cisco 6015 System*.

Tip

See the [“Cisco 6015 with a POTS Splitter Configuration” section on page 1-5](#) for more information about Cisco 6015 with a POTS splitter configuration components.

3.1 Installation Checklist

When you install a Cisco 6015 with a POTS splitter configuration in a commercial environment, be sure that you follow the installation procedures in the proper sequence. [Table 3-1](#) is a checklist of the installation steps in the order in which they should occur. Detailed installation instructions are discussed in the sections following [Table 3-1](#).

Table 3-1 *Installation Checklist—Cisco 6015 with a POTS Splitter Configuration in a Commercial Environment*

Check	Installation Procedure
	1. Measure the required rack space.
	2. Install the POTS splitter(s) in the rack.
	3. Install the AC/DC converter and converter tray in the rack, if applicable.
	4. Install the Cisco 6015 chassis in the rack.
	5. Install the blank faceplates in the open slots.
	6. Ground the Cisco 6015 chassis and POTS splitter(s).
	7. Connect the DC PEM ¹ to the AC/DC converter, if you are using AC power.
	8. Connect the DC PEM to the fuse and alarm panel, if you are using DC power.
	9. Connect the BITS ² interface, if applicable.
	10. Connect the facility alarm input, if applicable.
	11. Connect the DSL interface module to the POTS splitter(s).
	12. Connect the POTS splitter(s) to the MDF ³ .
	13. Connect the I/O ⁴ module on the subtending host chassis to the I/O module on the subtended node chassis (optional). Note This step is necessary only when installing a subtended network configuration. For an OC-3c/OC-3c NI-2 card subtended network configuration, the network connections are made through the faceplates of the OC-3c/OC-3c NI-2 cards, not the I/O modules.
	14. Connect the I/O module to the network. Note If you have an OC-3c/OC-3c NI-2 card installed in your system, the network connection is made through the NI-2 card faceplate, not the I/O module.
	15. Apply power to the system.
	16. Verify that the fan modules are operational.
	17. Install the POTS cards.
	18. Connect the Ethernet to the management network.
	19. Connect a console terminal.
	20. Connect the auxiliary port (optional).
	21. Complete initial configuration.

1. PEM = power entry module
2. BITS = building integrated timing supply
3. MDF = main distribution frame
4. I/O = Input/Output

3.2 Installation Procedures

The following sections detail the installation procedures for a Cisco 6015 with a POTS splitter configuration in a commercial environment.

**Caution**

Proper ESD protection is required whenever you handle Cisco equipment. Installation and maintenance personnel should be properly grounded using ground straps to eliminate the risk of ESD damage to the equipment. Cards are subject to ESD damage whenever they are removed from the chassis.

See the “[Preventing Electrostatic Discharge Damage](#)” section on page 2-9 for ESD grounding jack locations on the Cisco 6015 system.

3.2.1 Measure Required Rack Space

For the rack to remain stable, you must install your Cisco 6015 system from the bottom to the top of the rack. Before you install any of the chassis, determine the total rack space that is required to install your system. The required rack space depends on the type of line cards installed and the number of Cisco 6015 chassis, AC/DC converters, and POTS splitters that you plan to use. The number of components will increase if you plan to install a subtended network.

You can install a combination of the following Cisco 6015 components in a 7-foot rack:

- Cisco 6015 chassis.
 - If you are installing quad-port flexi ATU-C line cards (4xflexis), the maximum is nine chassis per rack (include subtending host and subtended node chassis).
 - If you are installing octal-port discrete multitone (DMT) ATU-C line cards (8xDMTs) or octal-port DMT ATU-C over ISDN line cards (8xDMT over ISDNs), the maximum is six chassis per rack (include subtending host and subtended node chassis).
- AC/DC converter and converter tray—Optional.
- Third-party POTS splitter.

**Note**

Third-party POTS splitters can be installed in a Cisco 6015 with a POTS splitter configuration. Please verify the compatibility of your third-party POTS splitter with your Cisco representative.

In a system configuration using 4xflexis, install only one POTS splitter.

In a system configuration using 8xDMTs or 8xDMT over ISDNs, the system requires a POTS splitter that expands the system capacity to 48 subscriber ports. Depending on the POTS splitter selected for your configuration, the installation of an additional POTS splitter may be necessary.

**Tip**

See [Chapter 2, “Preparing for Installation,”](#) for the calculation tables that are necessary to plan the total rack space for your Cisco 6015 system configuration.

The Cisco 6015 system fits in either a 19-inch or a 23-inch wide rack. See [Table 2-3](#) for individual rack space requirements.

**Warning**

To prevent bodily injury when mounting or servicing this unit in a rack, you must take special precautions to ensure that the system remains stable. The following guidelines are provided to ensure your safety:

—This unit should be mounted at the bottom of the rack if it is the only unit in the rack.

—When mounting this unit in a partially filled rack, load the rack from the bottom to the top with the heaviest component at the bottom of the rack.

—If the rack is provided with stabilizing devices, install the stabilizers before mounting or servicing the unit in the rack.

If you plan to expand your system to include more chassis in the future, allow space in the rack for additions during the initial installation, keeping in mind the weight distribution and stability of the rack.

3.2.2 Install the POTS Splitter

You can use third-party POTS splitters in a Cisco 6015 with a POTS splitter configuration. Please verify the compatibility of your third-party POTS splitter with your Cisco representative.



Note In a system configuration using 4xflexis, install only one POTS splitter.

In a system configuration using 8xDMTs or 8xDMT over ISDNs, the system requires a POTS splitter that expands the system capacity to 48 subscriber ports. Depending on the POTS splitter selected for your configuration, the installation of an additional POTS splitter may be necessary.

For installation procedures for each POTS splitter, refer to the vendor documentation.

See [Figure 1-2](#) for the correct placement of the POTS splitters.

3.2.3 Install the AC/DC Converter and Converter Tray

If you are using AC power, complete the following steps to install the AC/DC converter. If you are not using AC power, proceed to the [“Install the Cisco 6015 Chassis”](#) section on page 3-5.

-
- Step 1** Use four mounting screws and a Phillips-head screwdriver to attach the extenders to the sides of the tray if you are installing the system in a 23-inch rack.
 - Step 2** Position an AC/DC converter tray, which occupies 1 RU of space, above the POTS splitter.
The bottom of the tray should be flush with the top of the POTS splitter.
 - Step 3** Use four mounting screws and a Phillips-head screwdriver to bolt the tray in the rack.
 - Step 4** Slide an AC/DC converter into one of the three open slots.
 - Step 5** Use a Phillips-head or flat-head screwdriver to attach the screw that secures the AC/DC converter in the tray.

Figure 3-1 shows the screw locations on the tray.

Figure 3-1 Screw Locations for the AC/DC Converter Tray

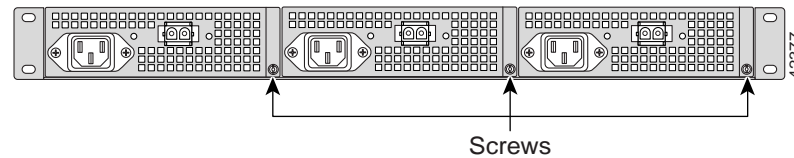

3.2.4 Install the Cisco 6015 Chassis

Complete the following steps to install the Cisco 6015 chassis.



Warning

Two people are required to lift the chassis. Grasp the chassis underneath the lower edge and lift with both hands. To prevent injury, keep your back straight and lift with your legs, not your back. To prevent damage to the chassis and components, never attempt to lift the chassis with the handles on the power supplies or on the interface modules. These handles were not designed to support the weight of the chassis.



Note

The Cisco 6015 chassis ships with the cards and modules installed. To prevent damage, ensure that the screws on each card and module are tightened so that the cards do not fall out of the chassis during installation.

- Step 1** Position one Cisco 6015, which occupies 3 RUs of space, above the AC/DC converter or the POTS splitter. The bottom of the Cisco 6015 chassis should be flush with the top of the AC/DC converter or POTS splitter.
- Step 2** Use four mounting screws and a Phillips-head screwdriver to attach the extenders to the sides of the chassis if you are installing the system in a 23-inch rack, as shown in [Figure 3-2](#).

Figure 3-2 Extender Installation on the Cisco 6015

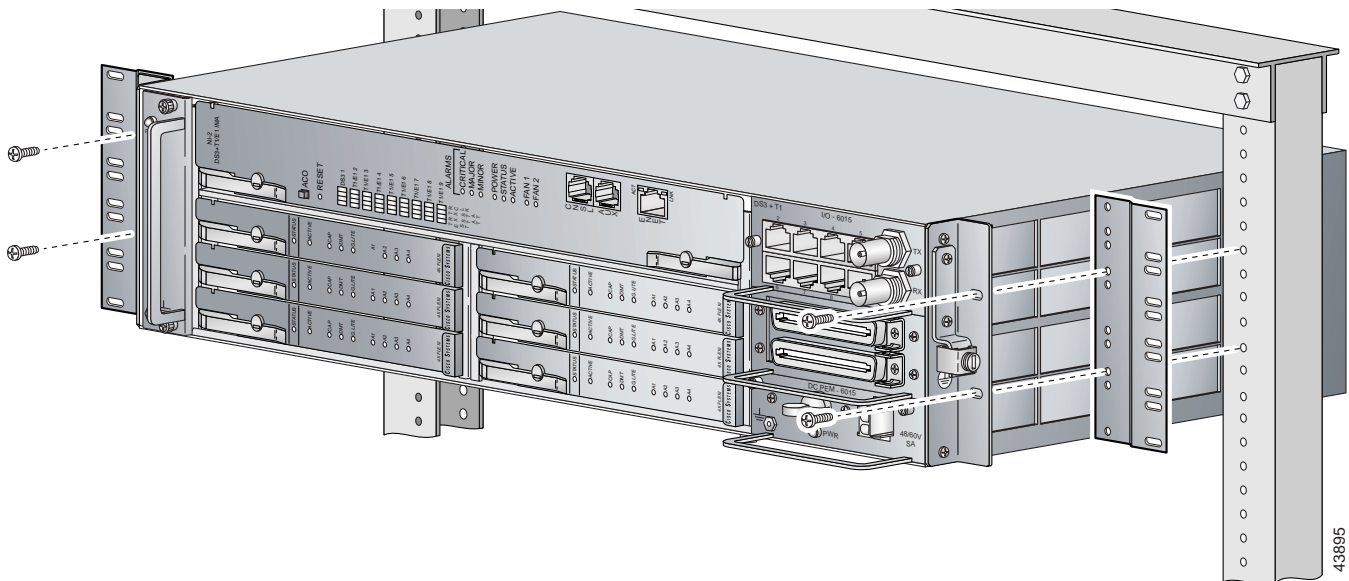

- Step 3** Use four mounting screws and a Phillips-head screwdriver to attach the Cisco 6015 to the rack.
- Step 4** Repeat [Step 1](#) through [Step 3](#) for each Cisco 6015, as necessary.
- See [Figure 1-2](#) for the correct placement of the Cisco 6015.

3.2.5 Install Blank Faceplates

Blank faceplates should occupy any empty line card slots in the Cisco 6015 chassis. Blank faceplate installation is similar to line card installation.



Warning

Blank faceplates and cover panels serve three important functions: they prevent exposure to hazardous voltages and currents inside the chassis; they contain electromagnetic interference (EMI) that might disrupt other equipment; and they direct the flow of cooling air through the chassis. Do not operate the system unless all cards, faceplates, front covers, and rear covers are in place.

Complete the following steps to install blank faceplates in any empty line card slots in the Cisco 6015:

- Step 1** Connect a grounding strap to an ESD grounding jack on the Cisco 6015. See the [“Preventing Electrostatic Discharge Damage”](#) section on [page 2-9](#) for ESD grounding jack locations on the Cisco 6015 system.
- Step 2** Horizontally align the blank faceplate edge with the guides at the left and right of the slot.
- Step 3** Lift out on the ejector tab and gently apply pressure to the faceplate while pushing the blank faceplate into the slot.

- Step 4 Push on the faceplate to fully seat the blank faceplate.
- Step 5 Press down on the ejector tab to secure the faceplate.

3.2.6 Ground the Cisco 6015 and POTS Splitter(s)

Complete the following steps to connect the grounding lug on the Cisco 6015 and POTS splitter(s) directly to the rack:



Warning

When installing the unit, always make the ground connection first and disconnect it last.

- Step 1 Remove all paint or oxidation from the rack at the point of the grounding connection.
- Step 2 Measure enough wire to connect the Cisco 6015 to the rack. See [Table 2-6 on page 2-19](#) for wire requirements.



Tip

Make sure that your wire is only as long as is needed to make the connection.

- Step 3 Cut the ends of the ground wire so that the ends are straight, not slanted.
- Step 4 Measure 1/2 inch (12.7 mm) up from the end of the ground wire and place a mark at that point. This is the wire end that will be connected to the Cisco 6015.
- Step 5 Use a wire stripper to remove 1/2 inch (12.7 mm) of the covering from the end of the wire. Trim the end of the covering so that it is straight, not slanted, as shown in [Figure 3-3](#).

Figure 3-3 Strip and Square Off Ground Wire

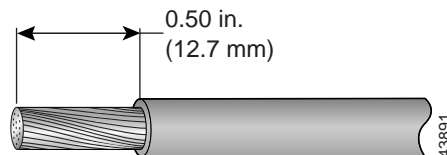

- Step 6 Use a flat-head screwdriver to loosen the compression screw (open position) that is provided on the grounding lug of the Cisco 6015, as shown in [Figure 3-4](#).

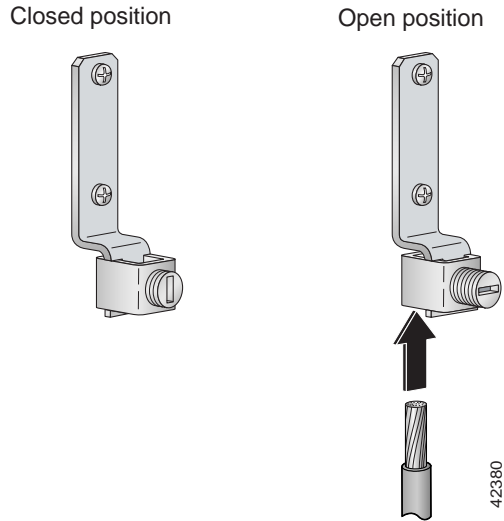
Figure 3-4 Grounding Lug Closed and Open Positions

The Cisco 6015 grounding lug is located on the right side of the chassis (if viewed from the front), as shown in [Figure 3-5](#).

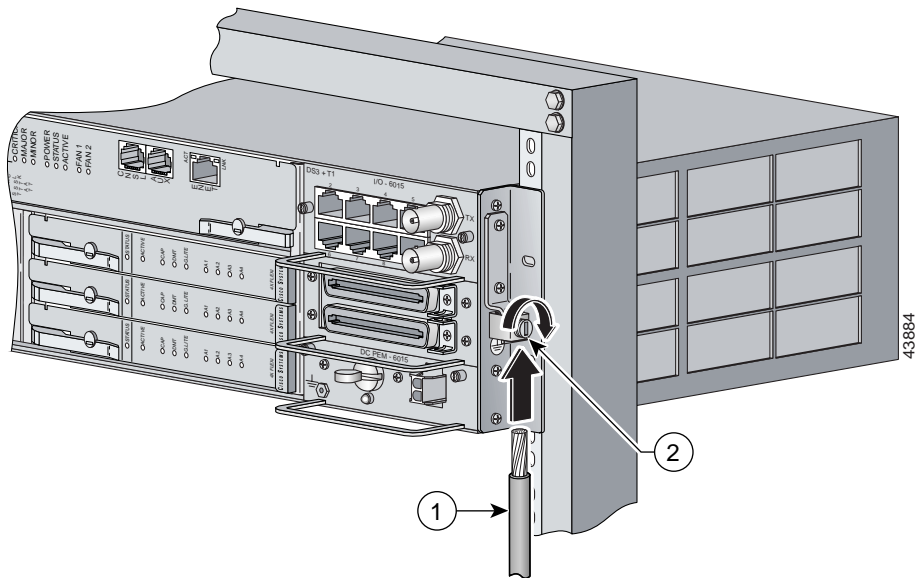
Figure 3-5 Attaching the Grounding Wire to the Cisco 6015

1	Grounding wire	2	Grounding lug
---	----------------	---	---------------

Step 7 Insert the end of the copper wire that you prepared in [Step 5](#) under the compression plate on the grounding lug, as shown in [Figure 3-4](#).



Caution

Do not place the copper wire between the compression screw and the compression plate.

- Step 8** Use a flat-head screwdriver to tighten the compression screw against the compression plate, as shown in [Figure 3-4](#).
- Step 9** Prepare the other end of the wire to be connected to the rack, according to the requirements of your site.
- Step 10** Use a flat-head screwdriver to loosen the screw on the rack.
- Step 11** Connect the copper wire to a ring lug (large enough for the rack screw to fit through).
- Step 12** Use a flat-head screwdriver and the screw that you loosened in [Step 10](#) to attach the ring lug to the rack, as shown in [Figure 3-6](#).

Figure 3-6 Attaching the Grounding Wire to the Rack

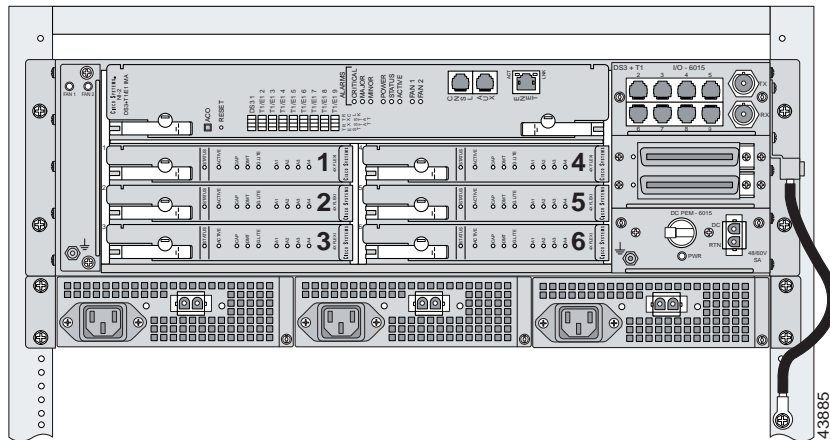

- Step 13** Use a flat-head screwdriver to tighten the rack screw over the copper wire.
- Step 14** Repeat [Step 1](#) through [Step 13](#) for each Cisco 6015, as necessary.
- Step 15** Ground each POTS splitter.

For wire specifications and procedures for grounding each POTS splitter, refer to the vendor documentation.



Note Do not ground the components in a rack by chaining them together.

3.2.7 Connect the DC PEM to the AC/DC Converter

If you are using AC power, complete the following steps to connect the DC PEM to the AC/DC converter. If you are using DC power, proceed to the [“Connect the DC PEM to the Fuse and Alarm Panel”](#) section on [page 3-10](#).

- Step 1** Attach one end of the DC power cable (part number 72-2178-01) to the 2-pin connector located on the faceplate of the DC PEM, as shown in [Figure 3-7](#).

Figure 3-7 Connecting the DC PEM to the AC/DC Converter

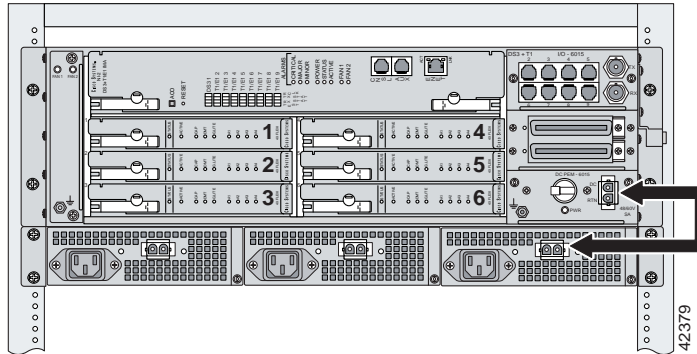

- Step 2** Attach the other end of the cable to the 2-pin connector located on the faceplate of the AC/DC converter, as shown in [Figure 3-7](#).
- Step 3** Repeat [Step 1](#) and [Step 2](#) for each Cisco 6015, as necessary.



Caution Do not plug in the AC power cord at this time.

3.2.8 Connect the DC PEM to the Fuse and Alarm Panel

If you are using DC power, complete the following steps to connect the DC PEM to the fuse and alarm panel. If you are using AC power, proceed to the [“Connect the BITS Interface”](#) section on [page 3-11](#).



Caution To prevent the system from powering up, do not install the fuses at this time. If the fuses are already installed in the fuse and alarm panel, remove them. You can replace the fuses after the system is installed and connected.



Note The fuse and alarm panel is not provided by Cisco.



Note Connect each Cisco 6015 system component to a separate fuse. Do not power the components in the rack by chaining them together.

See [Chapter 2, “Preparing for Installation,”](#) for the calculation tables that are necessary to determine the typical power requirement for each component that is wired to the fuse and alarm panel.

- Step 1** Attach one end of the DC power cable (part number 72-2223-01) to the 2-pin connector located on the faceplate of the DC PEM, as shown in [Figure 3-8](#).

Figure 3-8 Connecting the DC PEM to the Fuse and Alarm Panel

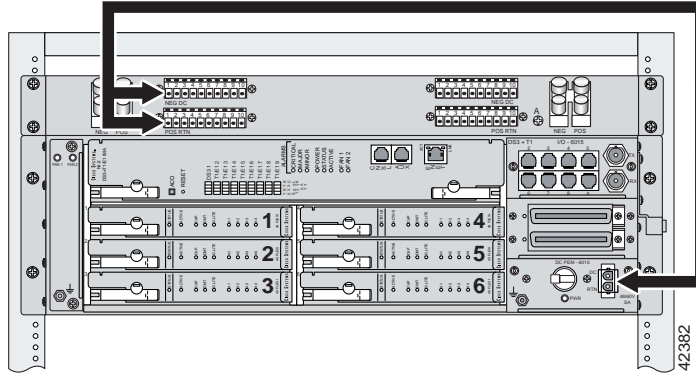

- Step 2** Attach the red wire coming from the DC PEM to a fuse and alarm panel POS (positive) DC connector, as shown in [Figure 3-8](#).
- Step 3** Attach the black wire coming from the DC PEM to a fuse and alarm panel NEG (negative) DC connector, as shown in [Figure 3-8](#).
- Step 4** Repeat [Step 1](#) through [Step 3](#) for each Cisco 6015, as necessary.



Caution

Do not set the circuit breaker on the DC PEM to the ON (1) position at this time.

3.2.9 Connect the BITS Interface

The BITS interface provides the network clocking. Complete the following steps to connect the BITS interface to the BITS clock source:



Note

For more information on the BITS interface, see the [“Rear Interface Header”](#) section on page 1-36.

- Step 1** Use a Phillips-head screwdriver to remove the three screws that hold the plate over the BITS interface pins, as shown in [Figure 3-9](#). Remove the plate, and set the screws and the plate aside.

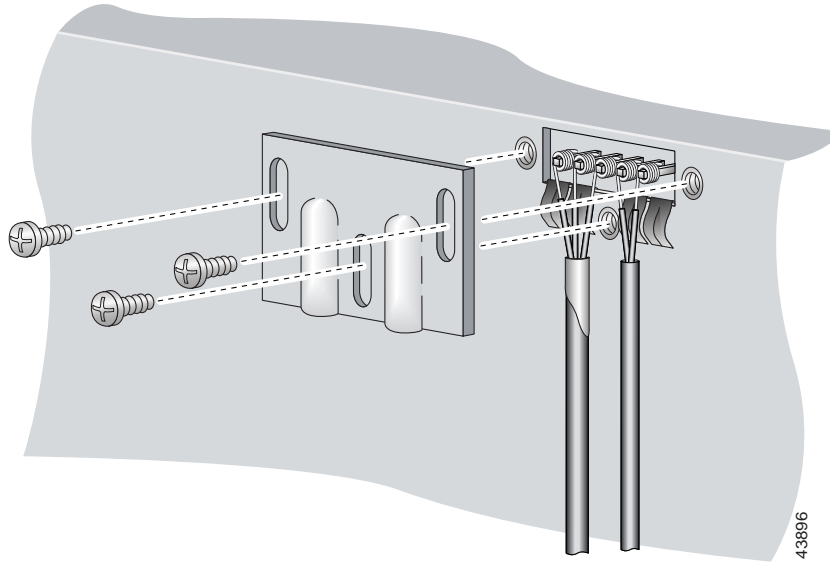
Figure 3-9 Plate Removal over BITS Interface Pinouts

- Step 2** Measure one strand of wire long enough to connect the first three BITS interface pins to the BITS clock source. See [Table 2-6 on page 2-19](#) for wire requirements.

See [Figure 3-10](#) for a close view of the pinouts that are located on the back of the Cisco 6015 chassis. For pinout descriptions, see [Table 1-8 on page 1-37](#).

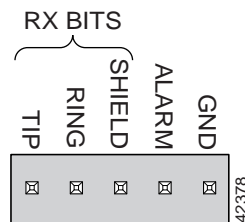
Figure 3-10 BITS Interface Pinouts

- Step 3** Use a wire stripper to remove the casing from both ends of the wire.
- Step 4** Pull the foil shield back over the wire casing and separate the three exposed wires, as shown in [Figure 3-9](#).
- Step 5** Use a wire-wrapping tool to attach the drain wire in the twisted-pair to pin 3 (Shield), as shown in [Figure 3-9](#).
- Step 6** Use a wire-wrapping tool to attach one of the two remaining wires in the twisted-pair to pin 2 (Ring), as shown in [Figure 3-9](#).
- Step 7** Use a wire-wrapping tool to attach the remaining wire in the twisted-pair to pin 1 (Tip), as shown in [Figure 3-9](#).
- Step 8** Use a Phillips-head screwdriver and three screws to reattach the plate that covers the BITS interface pins. Align the wires with the recessed channels on the plate so that the wires are not pinched when the plate is attached to the chassis, as shown in [Figure 3-11](#).



Note When the plate is reattached to the chassis, the bottom of the plate should reside in the middle of the foil shield, as shown in [Figure 3-11](#).

If you are going to connect the facility alarm input, do not reattach the plate at this time.

Figure 3-11 Wire Alignment Under the Plate

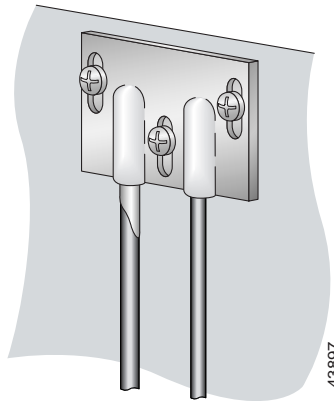

Step 9 Connect the other end of the wires from [Step 5](#) through [Step 7](#) to the BITS clock source.

Step 10 Repeat [Step 1](#) through [Step 9](#) for each Cisco 6015, as necessary.

3.2.10 Connect the Facility Alarm Input

Complete the following steps to connect the facility alarm input to the alarm relay contact:



Note For more information on the facility alarm input, see the [“Rear Interface Header”](#) section on page 1-36.

Step 1 Use a Phillips-head screwdriver to remove the three screws that hold the plate over the BITS interface pins, as shown in [Figure 3-12](#). Remove the plate, and set the screws and the plate aside.

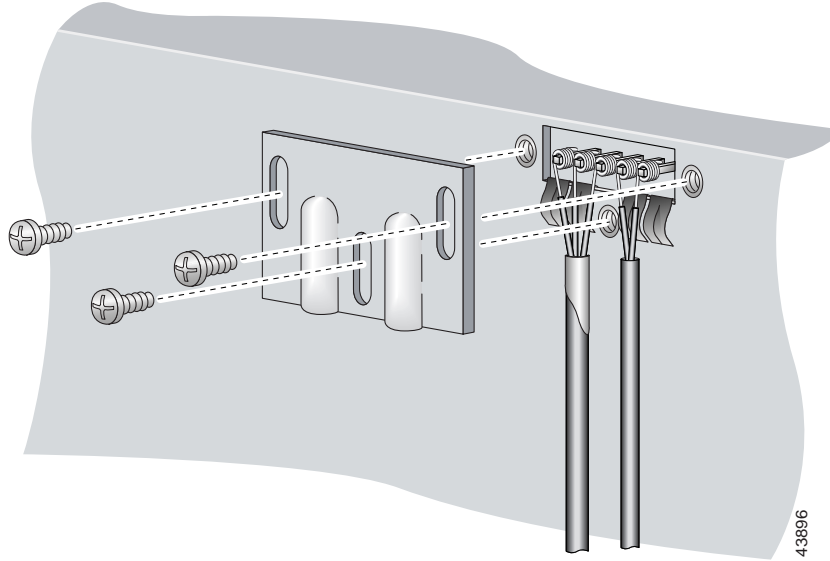

Note If you connected the BITS interface pins, skip this step and proceed to [Step 2](#).

Figure 3-12 Plate Removal Over Facility Alarm Input Pinouts

- Step 2** Measure wire long enough to connect both pins 4 and 5 to the alarm relay contact. See [Table 2-6 on page 2-19](#) for wire requirements.
- See [Figure 3-10](#) for a close-up of the pinouts that are located on the back of the Cisco 6015 chassis. For pinout descriptions, see [Table 1-8 on page 1-37](#).
- Step 3** Use a wire stripper to remove the casing from both ends of the wire.
- Step 4** Use a wire-wrapping tool to attach one of the wires to pin 4 (Alarm), as shown in [Figure 3-12](#).
- Step 5** Use a wire-wrapping tool to attach the remaining wire to pin 5 (Ground), as shown in [Figure 3-12](#).
- Step 6** Connect the relay activator to the alarm event trigger.
- Step 7** Use a Phillips-head screwdriver and three screws to reattach the plate that covers the BITS and alarm interface pins. Align the wires with the recessed channels on the plate so that the wires are not pinched when the plate is attached to the chassis, as shown in [Figure 3-13](#).

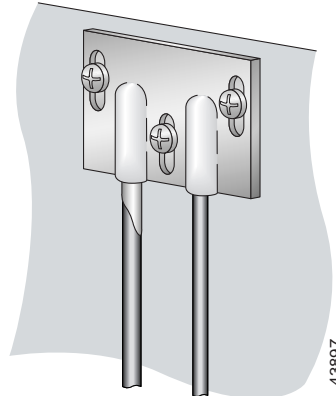

Note When the plate is reattached to the chassis, the bottom of the plate should reside in the middle of the foil shield for the BITS interface. The casing for the facility alarm input wire should be captured under the plate. (See [Figure 3-13](#).)

Figure 3-13 Wire Alignment Under the Plate

Step 8 Repeat [Step 1](#) through [Step 7](#) for each Cisco 6015, as necessary.

3.2.11 Connect the DSL Interface Module to the POTS Splitter(s)

You can use third-party POTS splitters in a Cisco 6015 with a POTS splitter configuration. Please verify the compatibility of your third-party POTS splitter with your Cisco representative.



Note

See [Table 2-6 on page 2-19](#) for cable and ferrite requirements. If unshielded cable is used for FCC Class A or EN55022 Class A compliance, the cables will need to be looped through ferrites.

For cabling procedures for each POTS splitter, refer to the vendor documentation.

[Figure 3-14](#) and [Figure 3-15](#) show examples of cabling between the DSL interface module and a third-party POTS splitter. These connections are for xDSL data flow between the Cisco 6015 and the third-party POTS splitter.

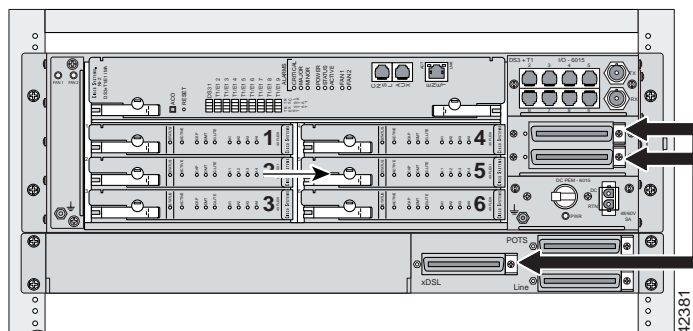
Figure 3-14 Connecting the DSL Interface Module to the POTS Splitter

A system configuration using 8xDMTs and 8xDMT over ISDNs requires a POTS splitter that expands the system capacity to 48 subscriber ports. Depending on the POTS splitter selected for your configuration, the installation of an additional POTS splitter may be necessary. [Figure 3-15](#) shows the cabling between the DSL interface module and two third-party POTS splitters. These connections are for xDSL data flow between the Cisco 6015 and the POTS splitters.

Figure 3-15 Connecting the DSL Interface Module to Two POTS Splitters

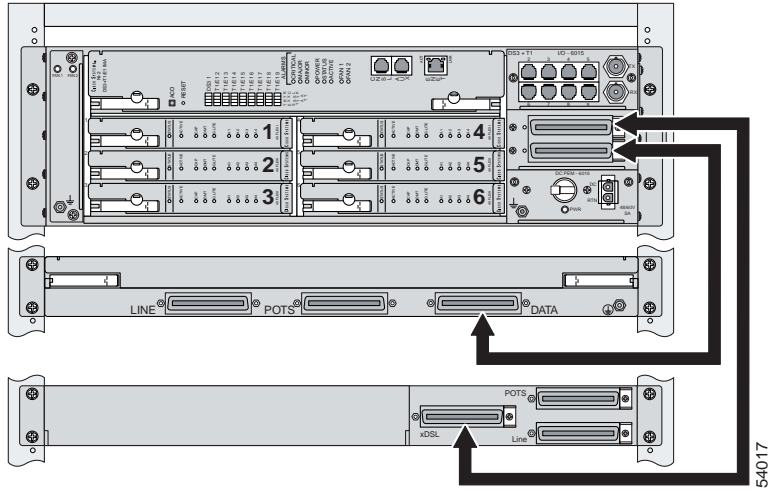

Ensure that all cables are screwed in and that the Champ connectors are tie wrapped. (See [Figure 3-16](#).)

Figure 3-16 Attaching a Champ Connector to the Chassis

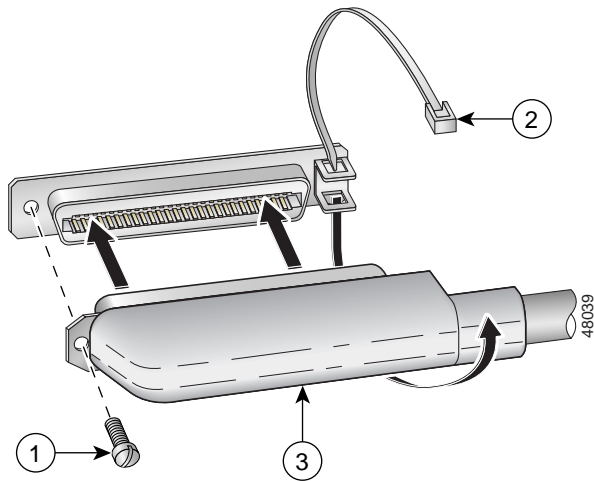

1	Champ connector screw	3	Champ connector
2	Tie wrap		

3.2.12 Connect the POTS Splitter(s) to the MDF

You can use different third-party POTS splitters in a Cisco 6015 with a POTS splitter configuration. Please verify the compatibility of your third-party POTS splitter with your Cisco representative.

For cabling procedures for each POTS splitter, refer to the appropriate vendor documentation.



Note

See [Table 2-6 on page 2-19](#) for cable and ferrite requirements. If unshielded cable is used for FCC Class A or EN55022 Class A compliance, the cables will need to be looped through ferrites.

3.2.13 Install a Subtended Network Configuration

If you are installing a subtended network, complete the following steps. If you are not installing a subtended network, proceed to the [“Connect the Cisco 6015 to the Network” section on page 3-19](#).

The following sections provide installation procedures for subtended network configurations using the DS3+T1/E1 IMA NI-2 card and the OC-3c/OC-3c NI-2 card.



Tip

The term *subtending* refers to the host chassis, and *subtended* refers to the downstream chassis in a subtended network.

Cisco recommends that you label each data cable at both ends to identify its destination.



Note

For more information on a subtended network configuration, see the [“Subtended Network Configuration” section on page 1-6](#).

See [Table 2-6 on page 2-19](#) for cable and ferrite requirements. If unshielded cable is used for FCC Class B or EN55022 Class B compliance, the cables will need to be looped through ferrites.

3.2.13.1 Connect the DS3+T1/E1 Subtending Network Configuration

Connections for T1 cabling are located on the DS3+T1 I/O module. The DS3+T1 I/O module is used in North America. Connections for E1 cabling are located on the E1 I/O module. The E1 I/O module is used world-wide, except in North America.

The TX and RX RJ-48 T1/E1 connectors on the subtending host chassis I/O module are connected to the TX and RX RJ-48 T1/E1 connectors on the subtended node chassis I/O module.



Note

The E1 I/O module is used in world-wide environments, except in North America. The E1 I/O module has eight RJ-48 receptacles for eight E1 trunk or subtending interfaces.

Complete the following steps to cable the I/O module for T1/E1 subtending:

-
- Step 1** Verify that you have either DS3+T1 I/O modules or E1 I/O modules installed on your subtending host and node chassis.
- Step 2** Connect one end of an RJ-48 cable to one of the RJ-48 receptacles on the I/O module in the subtending host chassis.
- Step 3** Connect the other end of the RJ-48 cable to one of the RJ-48 receptacles on the I/O module in a subtended node chassis.

Figure 3-17 shows an example of a subtended network configuration.

Figure 3-17 DS3+T1 Subtended Network Configuration

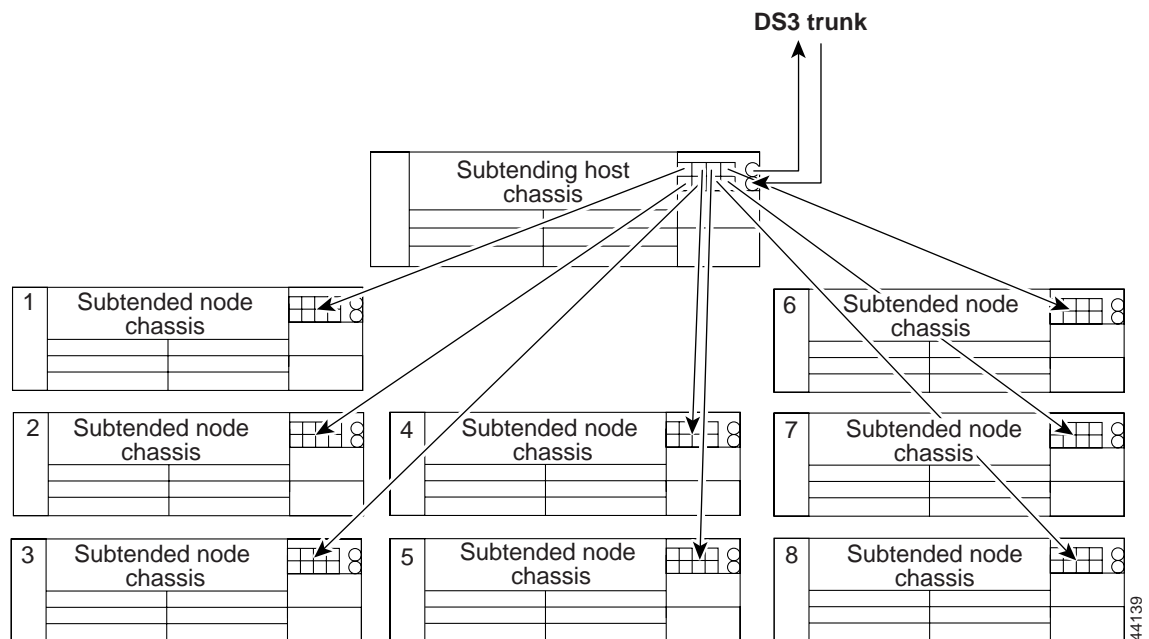

- Step 4** Repeat [Step 2](#) through [Step 3](#) to connect the subtending host chassis to each subtended node chassis.



Note If you are using a T1 or E1 trunk to the network, the trunk connection will originate at one of the RJ-48 receptacles on the DS3+T1 I/O module or the E1 I/O module on the host chassis. Therefore, only seven RJ-48 receptacles will be available for subtending connections.

3.2.13.2 Connect the IMA Subtending Network Configuration

See the “[IMA Configuration](#)” section on page 1-8 for more information on how to configure an IMA subtending network configuration.

3.2.13.3 Connect the OC-3c Subtending Network Configuration

For OC-3c subtending, the connections are made from the OC-3c/OC-3c NI-2 cards in the subtending host chassis and the subtended node chassis. Connect one subtended Cisco 6015 to the subtending interfaces on the NI-2 (OC-3c interfaces).

To cable the Cisco 6015 system for OC-3c subtending, complete the following steps:

- Step 1** Verify that you have OC-3c/OC-3c NI-2 cards installed in the subtending host and node chassis.
- Step 2** Locate the trunk 1 interface connectors (TX and RX) and the subtend 2 interface connectors (TX and RX) on the front of each OC-3c/OC-3c NI-2 card.
- Step 3** Attach an OC-3c fiber-optic cable to the TX subtend 2 interface connector in the inset on the faceplate of the OC-3c/OC-3c NI-2 card in the subtending host chassis.
- Step 4** Attach the other end of the cable that you used in Step 2 to the RX trunk 1 interface connector in the inset on the faceplate of the OC-3c/OC-3c NI-2 card in the subtended node chassis.
- Step 5** Attach an OC-3c fiber-optic cable to the RX subtend 2 interface connector in the inset on the faceplate of the OC-3c/OC-3c NI-2 card in the subtending host chassis.
- Step 6** Attach the other end of the cable that you used in Step 4 to the TX trunk 1 interface connector in the inset on the faceplate of the OC-3c/OC-3c NI-2 card in the second subtended node chassis.

Figure 3-18 shows the OC-3c subtending connections between three Cisco 6015 system chassis.

Figure 3-18 Daisy Chain Topology for OC-3c/STM-1 Interfaces

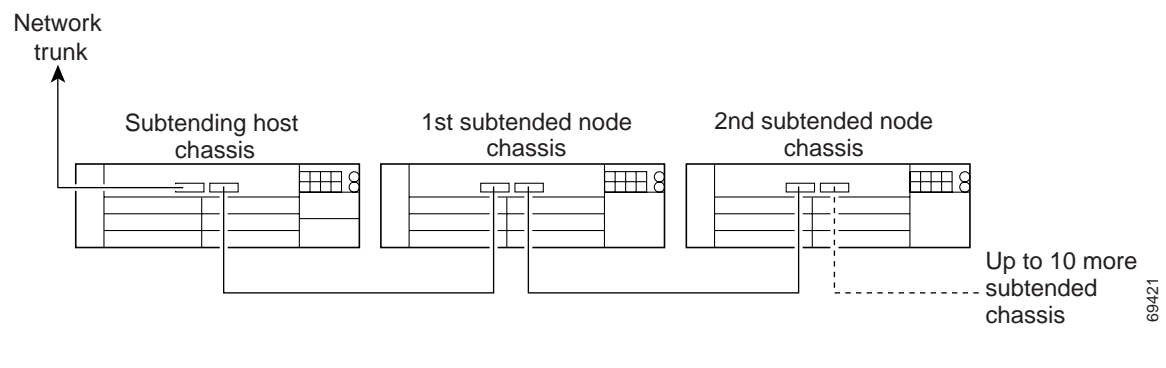

3.2.14 Connect the Cisco 6015 to the Network

The following sections detail the connection procedures for a DS3, T1, E1, IMA group, or OC-3c network connection.

3.2.14.1 DS3 Network Connection Installation

Complete the following steps to connect the I/O module to the network using a DS3 connection. If you are using a T1 connection, proceed to the [“T1 Network Connection Installation”](#) section on page 3-20. If you are using an E1 connection, proceed to the [“E1 Network Connection Installation”](#) section on

[page 3-21](#). If you are using an IMA connection, proceed to the [“IMA Network Connection Installation” section on page 3-21](#). If you are using an OC-3c connection, proceed to the [“OC-3c Network Connection Installation” section on page 3-21](#).

**Tip**

Cisco recommends that you label each data cable at both ends to identify its destination.

Step 1 Verify that you have a DS3+T1 I/O module installed in the Cisco 6015 chassis.

The I/O module DS3 connections attach to the ATM switch. Two 75-ohm DS3 Bayonet-Neill-Concelman (BNC) connectors are provided for DS3 TX and RX. Attach one end of a coaxial cable (type 734A or equivalent) to the TX DS3 BNC connector on the I/O module.

**Note**

See [Table 2-6 on page 2-19](#) for cable requirements.

Step 2 Attach the other end of the cable that originates at the TX DS3 BNC connector to the RX DS3 BNC connector on the ATM switch.

Step 3 Attach one end of a coaxial cable (type 734A or equivalent) to the RX DS3 BNC connector on the I/O module.

Step 4 Attach the other end of the cable that originates at the RX DS3 BNC connector to the TX DS3 BNC connector on the ATM switch.

Step 5 Repeat [Step 1](#) through [Step 4](#) for each Cisco 6015, as necessary.

3.2.14.2 T1 Network Connection Installation

Complete the following steps to connect the I/O module to the network using a T1 connection. If you are using an E1 connection, proceed to the [“E1 Network Connection Installation” section on page 3-21](#). If you are using an IMA connection, proceed to the [“IMA Network Connection Installation” section on page 3-21](#). If you are using an OC-3c connection, proceed to the [“OC-3c Network Connection Installation” section on page 3-21](#).

**Tip**

Cisco recommends that you label each data cable at both ends to identify its destination.

Step 1 Verify that you have a DS3+T1 I/O module installed in the Cisco 6015 chassis.

Step 2 Connect one end of an RJ-48 cable to one of the RJ-48 receptacles on the I/O module. If you have a subtended network configuration installed, this connection must be made from the I/O module in the subtending host chassis.

**Note**

See [Table 2-6 on page 2-19](#) for cable and ferrite requirements. If unshielded cable is used for FCC Class B or EN55022 Class B compliance, the cables will need to be looped through ferrites.

Step 3 Connect the other end of the cable used in [Step 2](#) to the ATM switch.

Step 4 Repeat [Step 1](#) through [Step 3](#) for each Cisco 6015, as necessary.



Note Verify that the RJ-48 cable pinouts connect TX to RX and RX to TX.

3.2.14.3 E1 Network Connection Installation

Complete the following steps to connect the I/O module to the network using an E1 connection. If you are using an IMA connection, proceed to the [“IMA Network Connection Installation” section on page 3-21](#). If you are using an OC-3c connection, proceed to the [“OC-3c Network Connection Installation” section on page 3-21](#).



Tip Cisco recommends that you label each data cable at both ends to identify its destination.

Step 1 Verify that you have an E1 I/O module installed in the Cisco 6015 chassis.

Step 2 Connect one end of an RJ-48 cable to one of the RJ-48 receptacles on the I/O module. If you have a subtended network configuration installed, this connection must be made from the I/O module in the subtending host chassis.



Note See [Table 2-6 on page 2-19](#) for cable and ferrite requirements. If unshielded cable is used for FCC Class B or EN55022 Class B compliance, the cables will need to be looped through ferrites.

Step 3 Connect the other end of the cable used in [Step 2](#) to the ATM switch.

Step 4 Repeat [Step 1](#) through [Step 3](#) for each Cisco 6015, as necessary.



Note Verify that the RJ-48 cable pinouts connect TX to RX and RX to TX.

3.2.14.4 IMA Network Connection Installation

See the [“IMA Configuration” section on page 1-8](#) for more information on how to configure an IMA network connection.

3.2.14.5 OC-3c Network Connection Installation

Complete the following steps to connect the OC-3c/OC-3c NI-2 card to the network.



Warning Do not stare into the beam or view it directly with optical instruments.

Step 1 Verify that you have an OC-3c/OC-3c NI-2 card installed in your Cisco 6015 chassis.

- Step 2** Attach the RX cable from the ATM switch to the TX connector in the inset on the faceplate of the OC-3c/OC-3c NI-2 card.
- The TX connector is the one closest to the top of the faceplate. The RX connector is closest to the bottom of the faceplate. The connector IDs are silkscreened inside the inset.
- Step 3** Attach the TX cable from the ATM switch to the RX connector in the inset on the faceplate of the OC-3c/OC-3c NI-2 card (trunk 1 interface connector RX). See [Figure 1-14 on page 1-27](#) for the OC-3c network interface connection location.
- Step 4** Repeat [Step 1](#) through [Step 3](#) for each Cisco 6015 chassis, as necessary.
-

3.2.15 Apply Power

The following sections detail the procedures to apply either AC or DC power.



Warning

Before working on equipment that is connected to power lines, remove jewelry (including rings, necklaces, and watches). Metal objects will heat up when connected to power and ground and can cause serious burns or weld the metal object to the terminals.

3.2.15.1 Apply AC Power

Complete the following steps to apply AC power to the Cisco 6015 system:

- Step 1** Attach the AC power cord to the AC/DC converter.
- Step 2** Plug the other end of the power cord into the wall outlet.



Caution

If the power connections are improperly made and power is applied while the cards are installed, the cards and chassis could be damaged.

- Step 3** Verify that the DC PEM is properly connected to the AC/DC converter, as described in the [“Connect the DC PEM to the AC/DC Converter”](#) section on page 3-9.
- Step 4** Set the circuit breaker on the DC PEM to the ON (1) position.
- Step 5** Verify that the DC PEM is operational by locating the LEDs on the front of the DC PEM. If the LED is
- Green—Output is correct.
 - Off—DC PEM is not operational. See [Chapter 6, “Troubleshooting”](#) for troubleshooting procedures.
- Step 6** Verify that the AC/DC converter is operational by locating the LEDs on the front of the AC/DC converter.
- If the left LED is green, this indicates that there is good AC input.
 - If the right LED is green, this indicates that there is good DC output from the DC PEM to the AC/DC converter.
 - If either LED is off, troubleshoot the AC/DC converter or the AC input.
-

3.2.15.2 Apply DC Power

Complete the following steps to apply DC power to the Cisco 6015 system:

-
- Step 1** Apply power to the system with one of the following methods:
- Install the fuses in the fuse and alarm panel.
 - Reinsert the fuses in the fuse and alarm panel if you removed them in the [“Connect the DC PEM to the Fuse and Alarm Panel”](#) section on page 3-10.
 - Turn on the breakers in the fuse and alarm panel.
-
-  **Caution** If the power connections are improperly made and power is applied while the cards are installed, the cards and chassis could be damaged.
-
- Step 2** Verify that the DC PEM is properly connected to the fuse and alarm panel as described in the [“Connect the DC PEM to the Fuse and Alarm Panel”](#) section on page 3-10.
- Step 3** Set the circuit breaker on the DC PEM to the ON (1) position.
- Step 4** Verify that the DC PEM is operational by locating the LEDs on the front of the DC PEM. If the LED is
- Green—Output is correct.
 - Off—DC PEM is not operational. See [Chapter 6, “Troubleshooting”](#) for troubleshooting procedures.
- Step 5** Check the polarity of the –48V DC connections to each chassis by attaching a voltmeter with the minus lead on the red wire and the plus lead on the black wire, at the fuse and alarm panel. Ensure that the meter reads between –40V DC and –68V DC. If your voltmeter shows a positive voltage, the power inputs might be reversed. If the voltmeter shows a negative voltage that is out of the –40V DC to –68V DC range, check the power supply for failure or check for a blown fuse in the fuse and alarm panel.
-

3.2.16 Verify Fan Module Operation

Verify that the fan module is operational by locating the LEDs on the front of the fan module. If the LEDs are

- Green—The fan module is operational.
- Red—The fan module is not operational and the fan module is in alarm mode. See [Chapter 6, “Troubleshooting”](#) for troubleshooting procedures.
- Off—The fan is not operational due to a power problem or the LED is defective. See [Chapter 6, “Troubleshooting”](#) for troubleshooting procedures.

The fans should be operational before you complete the installation procedures.

 **Caution**

It is important that the Cisco 6015 cooling fans run continuously.

3.2.17 Install the POTS Cards

For POTS card installation procedures for each POTS splitter, refer to the appropriate vendor documentation.

3.2.18 Connect the Ethernet to the Management Network

Complete the following steps to connect the Ethernet to the management network.



Warning

The ports labeled "Ethernet," "10BaseT," "Token Ring," "Console," and "AUX" are safety extra-low voltage (SELV) circuits. SELV circuits should only be connected to other SELV circuits. Because the BRI circuits are treated like telephone-network voltage, avoid connecting the SELV circuit to the telephone network voltage (TNV) circuits.



Tip

Cisco recommends that you label each data cable at both ends to identify its destination.

Step 1

Connect the 10BaseT RJ-45 connector to the NI-2 card ENET receptacle. [Figure 3-19](#) shows where to connect the Ethernet cable.



Note See [Table 2-6 on page 2-19](#) for cable and ferrite requirements.

Figure 3-19 ENET, CNSL, and AUX RJ-45 Receptacles on the DS3+T1/E1 IMA NI-2 Card

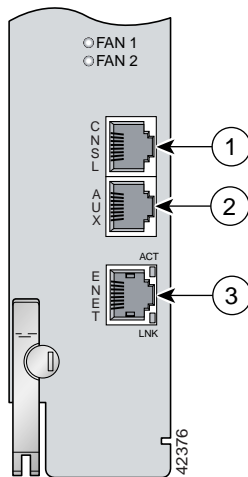

1	Console port	3	Ethernet port
2	Auxiliary port		

- Step 2** Run the cable through the ferrite one time, loop the cable back through the ferrite, and clamp the ferrite shut.
- Step 3** Connect the other end of the cable to the management network (for example, a LAN).

3.2.19 Connect a Console Terminal

Connect a VT100-compatible terminal to the system console port on the NI-2 card (CNSL). Connect the terminal to a power source and set it up using the values shown in [Table 3-2](#). [Figure 3-19](#) shows where to connect the console cable. See [Table 2-6 on page 2-19](#) for cable requirements.



Warning

The ports labeled "Ethernet," "10BaseT," "Token Ring," "Console," and "AUX" are safety extra-low voltage (SELV) circuits. SELV circuits should only be connected to other SELV circuits. Because the BRI circuits are treated like telephone-network voltage, avoid connecting the SELV circuit to the telephone network voltage (TNV) circuits.

Table 3-2 Terminal Settings

Baud rate	9600 (transmit and receive)
Character size	8 bits
Parity	None
Stop bits	1
Flow control	None

3.2.20 Connect the Auxiliary Port

Connect a terminal, a modem, or another serial device to the auxiliary port on the NI-2 card (AUX). [Figure 3-19](#) shows where to connect the auxiliary cable. See [Table 2-6 on page 2-19](#) for cable requirements.



Warning

The ports labeled "Ethernet," "10BaseT," "Token Ring," "Console," and "AUX" are safety extra-low voltage (SELV) circuits. SELV circuits should only be connected to other SELV circuits. Because the BRI circuits are treated like telephone-network voltage, avoid connecting the SELV circuit to the telephone network voltage (TNV) circuits.



Note

This step is optional.



Tip

Cisco recommends that you label each data cable at both ends to identify its destination.

3.2.21 Complete Initial Configuration

When you turn on the Cisco 6015 for the first time, an interactive dialog called the System Configuration Dialog appears on the console screen. The System Configuration Dialog guides you through the initial configuration process. (You can run the dialog at any time by entering the **setup** command in privileged EXEC mode.)

When you complete the dialog, the system displays the configuration command script that you have created. It then offers you three options:

[0] Go to the IOS command prompt without saving this config.

[1] Return back to the setup without saving this config.

[2] Save this configuration to nvram and exit.

If you enter **2**, the configuration is saved and used. If you answer **0** or **1**, the configuration you created is not saved. Enter **1** if you wish to discard the configuration and restart the System Configuration Dialog.



Note

Use the **show facility-alarm status** command to display any current alarms on the system.

The following is sample output of the **show facility-alarm status** command for the Cisco 6015:

```
System Totals  Critical: 1  Major: 0  Minor: 0
Source: ATM0/1          Severity: CRITICAL Description: 0    Loss of Signal
```

3.2.21.1 Before You Begin

Complete these steps before you run the System Configuration Dialog:

-
- Step 1** Determine the IP address for the Ethernet interface.
 - Step 2** If you plan to configure in-band management, also determine the IP address for the ATM interface that will be used for in-band management (ATM0/0).
 - Step 3** Find out what the password strategy is for your environment. The System Configuration Dialog prompts you for three passwords, plus an SNMP community string. The three required password types are enable secret, enable, and virtual terminal.
 - Step 4** Choose a name for the Cisco 6015. (This step is optional.)
-

3.2.21.2 Using the System Configuration Dialog

When you power up a Cisco 6015 for the first time, you are offered the option of running the System Configuration Dialog. The System Configuration Dialog offers two configuration options: basic management setup and extended setup.

- Choose basic management setup if you want to use the System Configuration Dialog to configure the passwords and the Ethernet interface only, and then use the management station or the command line interface to configure the remaining Cisco 6015 interfaces.

- Choose extended setup if you want to use the System Configuration Dialog to configure all of the Cisco 6015 interfaces.

An example of the use of each option follows the “[Interface Numbering](#)” section.

3.2.21.2.1 Interface Numbering

The System Configuration Dialog and the command line interface use the following interface numbering scheme:

- Interfaces whose names begin with “ATM0” (ATM0/1, ATM0/2, and so forth) are NI-2 card WAN interfaces. ATM0/0 is the ATM switch interface with the processor (sometimes referred to as the ASP interface, for ATM switch/processor). There is no need to configure ATM0/0 unless you plan to use in-band management. For DS3+T1, ATM0/1 is the default trunk port. ATM0/2 and through ATM0/9 can be used as trunk or subtending interfaces. For E1, ATM0/2 is the default trunk port. For IMA group interfaces using the DS3+T1/E1 IMA NI-2 card, one port from ATM0/ima0 through ATM0/ima3 can be the trunk port, with the other three being possible subtending interfaces.
- Interfaces whose names begin with “ATM1” through “ATM6” are line card interfaces.
- Ethernet0/0 is the interface for the LAN that connects the Cisco 6015 to its management system.

For dsl line card interfaces, the number before the slash indicates the slot number. The number after the slash indicates the interface or port number. For example, ATM6/4 is slot 6, port 4.

3.2.21.2.2 Basic Management Setup Example

This is the basic management setup example:

```

--- System Configuration Dialog ---

Would you like to enter the initial configuration dialog? [yes/no]: y

At any point you may enter a question mark '?' for help.
Use ctrl-c to abort configuration dialog at any prompt.
Default settings are in square brackets '['].

Basic management setup configures only enough connectivity
for management of the system, extended setup will ask you
to configure each interface on the system

Would you like to enter basic management setup? [yes/no]: y
Configuring global parameters:

Enter host name [DSLAM]: 6015_basic

The enable secret is a password used to protect access to
privileged EXEC and configuration modes. This password, after
entered, becomes encrypted in the configuration.
Enter enable secret: cisco

The enable password is used when you do not specify an
enable secret password, with some older software versions, and
some boot images.
Enter enable password: lab

The virtual terminal password is used to protect
access to the router over a network interface.
Enter virtual terminal password: lab
Configure SNMP Network Management? [yes]: y
Community string [public]:

```

Current interface summary

Any interface listed with OK? value "NO" does not have a valid configuration

Interface	IP-Address	OK?	Method	Status	Protocol
ATM0/0	unassigned	NO	unset	up	up
Ethernet0/0	unassigned	NO	unset	up	up
ATM0/1	unassigned	NO	unset	up	down
ATM0/2	unassigned	NO	unset	down	down
ATM0/3	unassigned	NO	unset	down	down
ATM0/4	unassigned	NO	unset	down	down
ATM0/5	unassigned	NO	unset	down	down
ATM0/6	unassigned	NO	unset	down	down
ATM0/7	unassigned	NO	unset	down	down
ATM0/8	unassigned	NO	unset	down	down
ATM0/9	unassigned	NO	unset	down	down
ATM0/IMA0	unassigned	NO	unset	up	up
ATM0/IMA1	unassigned	NO	unset	up	up
ATM0/IMA2	unassigned	NO	unset	up	up
ATM0/IMA3	unassigned	NO	unset	up	up

Enter interface name used to connect to the management network from the above interface summary: **ethernet0/0**

Configuring interface Ethernet0/0:

Configure IP on this interface? [yes]:

IP address for this interface: **192.168.1.1**

Subnet mask for this interface [255.255.255.0] : **255.255.255.0**

Class C network is 192.168.1.0, 24 subnet bits; mask is /24

The following configuration command script was created:

```
hostname 6015_basic
enable secret 5 $1$f1TA$jw/Rpe/EBj.fDQ3HYCjVw/
enable password lab
line vty 0 4
password lab
snmp-server community public
!
no ip routing

!
interface ATM0/0
shutdown
no ip address
!
interface Ethernet0/0
no shutdown
ip address 192.168.1.1 255.255.255.0
!
interface ATM0/1
shutdown
no ip address
!
interface ATM0/2
shutdown
no ip address
!
interface ATM0/3
shutdown
no ip address
!
interface ATM0/4
```

```
shutdown
no ip address
!
interface ATM0/5
shutdown
no ip address
!
interface ATM0/6
shutdown
no ip address
!
interface ATM0/7
shutdown
no ip address
!
interface ATM0/8
shutdown
no ip address
!
interface ATM0/9
shutdown
no ip address
!
interface ATM0/IMA0
shutdown
no ip address
!
interface ATM0/IMA1
shutdown
no ip address
!
interface ATM0/IMA2
shutdown
no ip address
!
interface ATM0/IMA3
shutdown
no ip address
!
end
```

```
[0] Go to the IOS command prompt without saving this config.
[1] Return back to the setup without saving this config.
[2] Save this configuration to nvram and exit.
```

```
Enter your selection [2]: 2
% Shutdown not allowed for ATM0/0.
Building configuration...
Use the enabled mode 'configure' command to modify this configuration.
```

Press RETURN to get started!

3.2.21.2.3 Extended Setup Example

This is the extended setup example:

```
--- System Configuration Dialog ---
```

```
Would you like to enter the initial configuration dialog? [yes/no]: y
```

At any point you may enter a question mark '?' for help.
Use ctrl-c to abort configuration dialog at any prompt.
Default settings are in square brackets '['].

Basic management setup configures only enough connectivity
for management of the system, extended setup will ask you
to configure each interface on the system

Would you like to enter basic management setup? [yes/no]: **n**

First, would you like to see the current interface summary? [yes]:

Any interface listed with OK? value "NO" does not have a valid configuration

Interface	IP-Address	OK?	Method	Status	Protocol
ATM0/0	unassigned	NO	unset	up	up
Ethernet0/0	unassigned	NO	unset	up	up
ATM0/1	unassigned	NO	unset	up	down
ATM0/2	unassigned	NO	unset	down	down
ATM0/3	unassigned	NO	unset	down	down
ATM0/4	unassigned	NO	unset	down	down
ATM0/5	unassigned	NO	unset	down	down
ATM0/6	unassigned	NO	unset	down	down
ATM0/7	unassigned	NO	unset	down	down
ATM0/8	unassigned	NO	unset	down	down
ATM0/9	unassigned	NO	unset	down	down
ATM0/IMA0	unassigned	NO	unset	up	up
ATM0/IMA1	unassigned	NO	unset	up	up
ATM0/IMA2	unassigned	NO	unset	up	up
ATM0/IMA3	unassigned	NO	unset	up	up

Configuring global parameters:

Enter host name [DSLAM]: **6015**

The enable secret is a password used to protect access to
privileged EXEC and configuration modes. This password, after
entered, becomes encrypted in the configuration.

Enter enable secret: **cisco**

The enable password is used when you do not specify an
enable secret password, with some older software versions, and
some boot images.

Enter enable password: **test**

The virtual terminal password is used to protect
access to the router over a network interface.

Enter virtual terminal password: **test**

Configure SNMP Network Management? [yes]:

Community string [public]:

Configure IP? [yes]:

Configure IGRP routing? [yes]: **n**

Configure RIP routing? [no]:

Configure CLNS? [no]:

Configure bridging? [no]:

Configuring interface parameters:

Do you want to configure ATM0/0 interface? [yes]: **n**

Do you want to configure Ethernet0/0 interface? [yes]:

Configure IP on this interface? [yes]:

IP address for this interface: **192.168.1.1**

```
Subnet mask for this interface [255.255.255.0] :  
Class C network is 192.168.1.0, 24 subnet bits; mask is /24
```

```
Do you want to configure ATM0/1 interface? [yes]:  
Configure IP on this interface? [yes]: n
```

```
Do you want to configure ATM0/2 interface? [yes]:  
Configure IP on this interface? [yes]: n
```

```
Do you want to configure ATM0/3 interface? [yes]: n
```

```
Do you want to configure ATM0/4 interface? [yes]: n
```

```
Do you want to configure ATM0/5 interface? [yes]: n
```

```
Do you want to configure ATM0/6 interface? [yes]: n
```

```
Do you want to configure ATM0/7 interface? [yes]: n
```

```
Do you want to configure ATM0/8 interface? [yes]: n
```

```
Do you want to configure ATM0/9 interface? [yes]: n
```

```
Do you want to configure ATM0/IMA0 interface? [yes]: n
```

```
Do you want to configure ATM0/IMA1 interface? [yes]: n
```

```
Do you want to configure ATM0/IMA2 interface? [yes]: n
```

```
Do you want to configure ATM0/IMA3 interface? [yes]: y
```

```
Configure IP on this interface? [yes]:
```

```
IP address for this interface: 192.168.2.1
```

```
Subnet mask for this interface [255.255.255.0] :
```

```
Class C network is 192.168.2.0, 24 subnet bits; mask is /24
```

```
The following configuration command script was created:
```

```
hostname 6015  
enable secret 5 $1$T768$ufaiopuEflcGFCG0VtmUV1  
enable password test  
line vty 0 4  
password test  
snmp-server community public  
!  
ip routing  
no clns routing  
no bridge 1  
!  
interface ATM0/0  
shutdown  
no ip address  
!  
interface Ethernet0/0  
ip address 192.168.1.1 255.255.255.0  
!  
interface ATM0/1  
no ip address  
!  
interface ATM0/2  
no ip address  
!  
interface ATM0/3  
shutdown  
no ip address
```

```

!
interface ATM0/4
shutdown
no ip address
!
interface ATM0/5
shutdown
no ip address
!
interface ATM0/6
shutdown
no ip address
!
interface ATM0/7
shutdown
no ip address
!
interface ATM0/8
shutdown
no ip address
!
interface ATM0/9
shutdown
no ip address
!
interface ATM0/IMA0
shutdown
no ip address
!
interface ATM0/IMA1
shutdown
no ip address
!
interface ATM0/IMA2
shutdown
no ip address
!
interface ATM0/IMA3
ip address 192.168.2.1 255.255.255.0
dialer-list 1 protocol ip permit
dialer-list 1 protocol ipx permit
!
end

```

[0] Go to the IOS command prompt without saving this config.

[1] Return back to the setup without saving this config.

[2] Save this configuration to nvram and exit.

Enter your selection [2]: **2**

% Shutdown not allowed for ATM0/0.

Building configuration...

Use the enabled mode 'configure' command to modify this configuration.

Press RETURN to get started!



Note

To configure your system, refer to the appropriate software or network management configuration guides.