



Cisco 6260 Fan Tray FRU Installation and Replacement Notes

Product Number: FANTRAY-6260=

This document provides the features and procedures for installing and removing the fan tray in the Cisco 6260 chassis. The fan tray is a field-replaceable unit (FRU).

Contents

This document includes the following sections:

- [Introduction, page 2](#)
- [Part and Tool Requirements, page 5](#)
- [General Safety Precautions and Maintenance Guidelines, page 5](#)
- [Removing and Installing the Fan Tray, page 9](#)
- [Fan Tray Maintenance, page 12](#)
- [Standards and Certifications, page 14](#)
- [Related Documentation, page 15](#)
- [Obtaining Documentation, page 15](#)
- [Obtaining Technical Assistance, page 16](#)

Introduction

Two fan trays are located below the subscriber line cards. Each tray houses four fans. The compartments for the two fan trays are located side by side near the bottom of the chassis, just above the power entry modules (PEMs). A narrow bezel fits across the chassis to hold the air filters and fan trays in place. [Figure 1](#) shows the location of the fan tray in the Cisco 6260 chassis.

Figure 1 Fan Tray Location in the Cisco 6260 Chassis

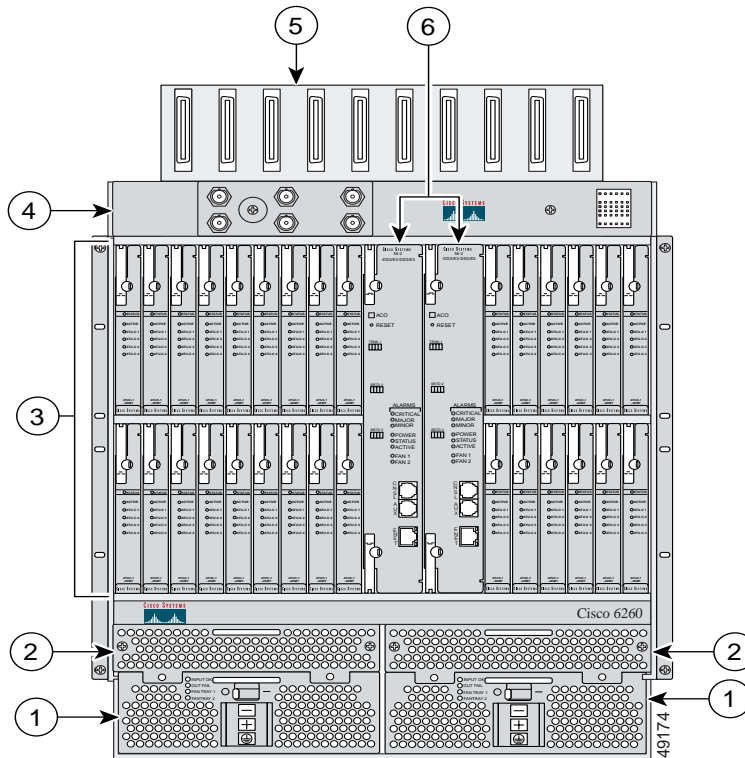

The Cisco 6260 system requires that a fan tray be installed when the system is in operation. [Figure 2](#) shows a close-up view of the fan tray.

Figure 2 Fan Tray for the Cisco 6260

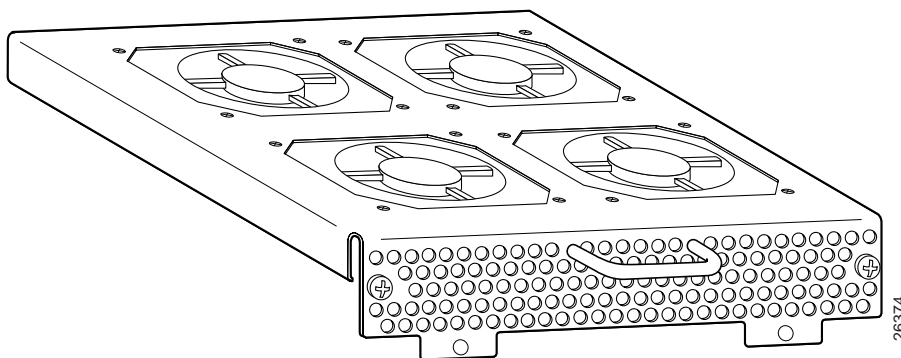

The fans have two speeds. By default, they run at low speed. The system turns up the fan speed when

- It senses high temperatures within the chassis.
- One or more fans fail.
- The other fan tray is removed.

The fan speed returns to normal (low speed) when

- Temperatures within the chassis fall to acceptable levels.
- A missing fan tray is returned to the chassis.



Caution

The cooling fans in both fan trays must run continuously. The system might suffer thermal damage if the fans in either tray stop for more than 5 minutes.

LEDs that report the status of the fan trays are located on the PEMs beneath the fan trays. [Table 1](#) details the fan tray status LEDs.

Table 1 *Fan Tray Status LEDs*

| LED | Color | Meaning |
|------------|-------|--|
| Fan Tray 1 | Green | The fans in this tray are operating normally. |
| | Red | One or more fans in this tray have failed. Replace the fan tray. |
| Fan Tray 2 | Green | The fans in this tray are operating normally. |
| | Red | One or more fans in this tray have failed. Replace the fan tray. |



Note

As you face the chassis, fan tray 1 is on the left; and fan tray 2 is on the right.

The fans pull cooling air from the bottom front of the chassis and blow the air up through the card cage. Figure 3 depicts the air flow through the Cisco 6260 chassis.

Figure 3 Air Flow Through Intake and Exhaust Vents on the Cisco 6260 Chassis.

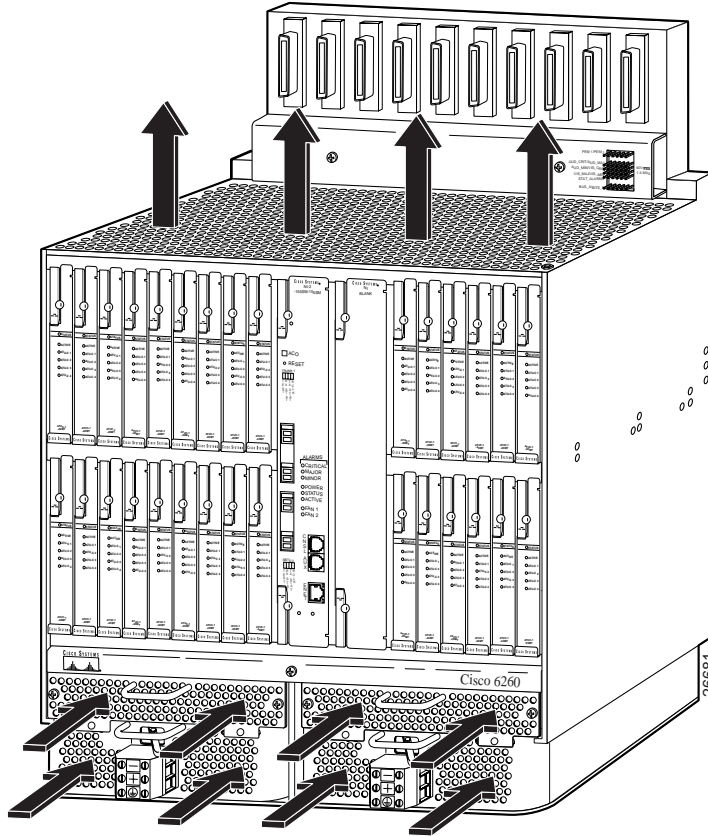

An air filter is located above each fan tray. The air filters must be removed and cleaned periodically. See the “[Fan Tray Maintenance](#)” section on page 12 for complete instructions on cleaning the air filters.

[Table 2](#) lists the specifications for the fan tray.

Table 2 Fan tray Specifications

| Specification | Description |
|---|--|
| Dimensions | Height: 1.5 in. (3.81 cm) Depth: 8.75 in. (22.23 cm) Width: 8.5 in. (21.59 cm) |
| Weight | 2.6 lb (1.18 kg) |
| Power consumption | 24W |
| Minimum software and network management requirement | Cisco IOS—Release 12.1(4)DA CDM—Release 3.2 (optional) |

Part and Tool Requirements

To install or replace the fan tray, you need the following parts and tools:

- Cisco 6260 fan tray.
- Necessary equipment for ESD protection—Required whenever you handle Cisco equipment, which includes the chassis, trays, and cards.
- No. 2 Phillips-head screwdriver.

General Safety Precautions and Maintenance Guidelines

This section describes the following areas:

- [General Safety Precautions, page 5](#)
- [General Maintenance Guidelines, page 8](#)
- [Preventing Electrostatic Discharge Damage, page 8](#)
- [Hot Swapping Trays, page 8](#)

General Safety Precautions

Before working on the equipment, be aware of standard safety guidelines and the hazards involved in working with electrical circuitry to prevent accidents. Adhere to the following cautions and warnings and those throughout the guide for safe and hazard-free installation.



Note

To see translations of the warnings that appear in this publication, refer to the *Regulatory Compliance and Safety Information for the Cisco 6260 System* document that accompanied this product.



Caution

Before you start the installation procedures, read the entire document for important information and safety warnings.



Caution

Proper ESD protection is required whenever you handle Cisco equipment. Installation and maintenance personnel should be properly grounded using ground straps to eliminate the risk of ESD damage to the equipment.



Caution

If the power connections are improperly connected and power is applied while the cards are installed, the cards and chassis could be damaged.



Caution

It is important that the chassis cooling fans run continuously while the system is powered.



Caution Any card that is only partially connected to the backplane can disrupt system operation.



Warning Only trained and qualified personnel should be allowed to install, replace, or service this equipment.



Warning Before opening the chassis, disconnect the telephone-network cables to avoid contact with telephone-network voltages



Warning To reduce the risk of fire, use only No. 26 AWG or larger telecommunication line cord.



Warning Blank faceplates and cover panels serve three important functions: they prevent exposure to hazardous voltages and currents inside the chassis; they contain electromagnetic interference (EMI) that might disrupt other equipment; and they direct the flow of cooling air through the chassis. Do not operate the system unless all cards, faceplates, front covers, and rear covers are in place.



Warning Do not use this product near water; for example, near a bathtub, washbowl, kitchen sink or laundry tub, in a wet basement, or near a swimming pool.



Warning Never install telephone wiring during an electrical storm.



Warning Never install telephone jacks in wet locations unless the jack is specifically designed for wet locations.



Warning Never touch uninsulated telephone wires or terminals unless the telephone line has been disconnected at the network interface.











Warning Use caution when installing or modifying telephone lines.



Warning Avoid using a telephone (other than a cordless type) during an electrical storm. There may be a remote risk of electric shock from lightning.



Warning Do not use a telephone to report a gas leak in the vicinity of the leak.

-  **Warning** Do not reach into a vacant slot or chassis while you install or remove a card, a tray, or a fan. Exposed circuitry could constitute an energy hazard.
-  **Warning** Do not work on the system or connect or disconnect cables during periods of lightning activity.
-  **Warning** The power supply circuitry for the equipment can constitute an energy hazard. Before you install or replace the equipment, remove all jewelry (including rings, necklaces, and watches). Metal objects can come into contact with exposed power supply wiring or circuitry inside the equipment. This could cause the metal objects to heat up and cause serious burns or weld the metal object to the equipment.
-  **Warning** Ultimate disposal of this product should be handled according to all national laws and regulations.
-  **Warning** Connect the unit only to a DC power source that complies with the Safety Extra-Low Voltage (SELV) requirements in IEC 60950 based safety standards.
-  **Warning** This equipment is to be installed and maintained by service personnel only as defined by AS/NZS 3260 Clause 1.2.14.3 Service Personnel.
-  **Warning** This product requires short-circuit (overcurrent) protection, to be provided as part of the building installation. Install only in accordance with national and local wiring regulations.
-  **Warning** VCCI Compliance for Class B Equipment (Japan).
- This is a Class B product based on the standard of the Voluntary Control Council for Interference from Information Technology Equipment (VCCI). If this is used near a radio or television receiver in a domestic environment, it may cause radio interference. Install and use the equipment according to the instruction manual.
-  **Warning** During line card installation, wear grounding wrist straps to avoid ESD damage to the card. Do not directly touch the backplane with your hand or any metal tool, or you could shock yourself.

General Maintenance Guidelines

This section covers

- [Installation and Replacement Suggestions, page 8](#)
- [Hot Swapping Trays, page 8](#)

Installation and Replacement Suggestions

The following examples list recommended installation and replacement practices for the Cisco 6260 system fan trays.



Any tray that is only partially connected to the backplane can disrupt system operation.

- Do not force the tray into its slot. This action can damage the pins on the backplane if they are not aligned properly with the tray.
- Ensure that the tray is straight and not at an angle when you install the tray in the slot. Installing the tray at an angle can damage the tray. Use the guide rails to install the tray correctly.

Hot Swapping Trays

Hot swapping allows you to remove and replace the tray without disconnecting the system power. The Cisco 6260 chassis supports hot swapping for the fan tray. Hot swapping the fan tray will not interrupt the service for any subscribers.



You need not turn off the power before removing a fan tray. However, if you must remove a fan tray from an operating Cisco 6260, replace it within 5 minutes. If that is not possible, shut the system down and turn off the power to avoid thermal damage.

Preventing Electrostatic Discharge Damage

Proper ESD protection is required whenever you handle Cisco equipment. ESD damage, which can occur when electronic cards or components are improperly handled, results in complete or intermittent failures. Use an antistatic strap during handling.

Follow these guidelines to prevent ESD damage:

- Always use an ESD wrist or ankle strap and ensure that it makes good skin contact.
- Connect the equipment end of the strap to the ESD jack on the front right side of the chassis.
- When you install a component, use available ejector levers or captive installation screws to seat the bus connectors in the backplane or midplane. Ejector levers and captive installation screws prevent accidental removal of components, provide proper grounding for the system, and help ensure that bus connectors are properly seated.
- When you remove a component, use available ejector levers or captive installation screws to release the bus connectors from the backplane or midplane.
- Handle the I/O module by the edges only; avoid touching the printed circuit boards or connectors.
- Avoid touching the printed circuit boards or connectors on the NI-2 cards or line cards.

- Place a removed component board-side-up on an antistatic surface or in a static-shielding container. If you plan to return the component to the factory, immediately place it in a static-shielding container.
- Avoid contact between the printed circuit boards and clothing. The wrist strap protects components from ESD voltages on the body only; ESD voltages on clothing can still cause damage.

**Caution**

Periodically check the resistance value of the antistatic strap. Ensure that the measurement is between 1 and 10 megohms.

Removing and Installing the Fan Tray

The following sections describe how to remove or install a fan tray.

**Caution**

Proper ESD protection is required whenever you handle Cisco equipment. Installation and maintenance personnel should be properly grounded using ground straps to eliminate the risk of ESD damage to the equipment. Modules are subject to ESD damage whenever they are removed from the chassis.

Removing the Fan Tray

Complete the following steps to remove the fan tray from the Cisco 6260 chassis:

**Note**

You need not turn off the power before removing a fan tray. However, if you must remove a fan tray from an operating Cisco 6260, replace it within 5 minutes. If that is not possible, shut the system down and turn off the power to avoid thermal damage.

**Caution**

If you do not have a replacement fan tray available, pull all of the line cards away from the backplane connection and power off the system until a replacement fan tray is available.

- Step 1** Connect a grounding strap to the ESD grounding jack that is located on the top right of the Cisco 6260 card cage.
- Step 2** Use a Phillips-head screwdriver to loosen the screw and remove the bezel that partially covers the fan trays.
- Step 3** Use a Phillips-head screwdriver to loosen the two captive screws on the fan tray.
- Step 4** Grasp the fan tray by the handle and pull it from the chassis. If the fans are running, you will hear them slow down as the tray disengages from its power connector.

**Caution**

The fans continue to turn at high speed for several seconds after the fan tray is removed from the chassis. To avoid injury to your hands, touch the fan tray only by its handle until the fans have stopped.

If there is a second fan tray in the chassis, you will hear it speed up when you remove the first fan tray. See the [“Installing the Fan Tray” section on page 10](#) for fan tray installation procedures.

Installing the Fan Tray

Complete the following steps to install the fan tray in the Cisco 6260 chassis:

-
- Step 1** Connect a grounding strap to the ESD grounding jack that is located on the top right of the Cisco 6260 chassis card cage.
 - Step 2** If the bezel is in place, use a Phillips screwdriver to remove it.
 - Step 3** Insert the fan tray into the chassis. Make sure that the pins in the lower lip of the fan tray front panel engage with the holes in the PEM below.

Figure 4 Cisco 6260 Chassis with Fan Trays and Bezel

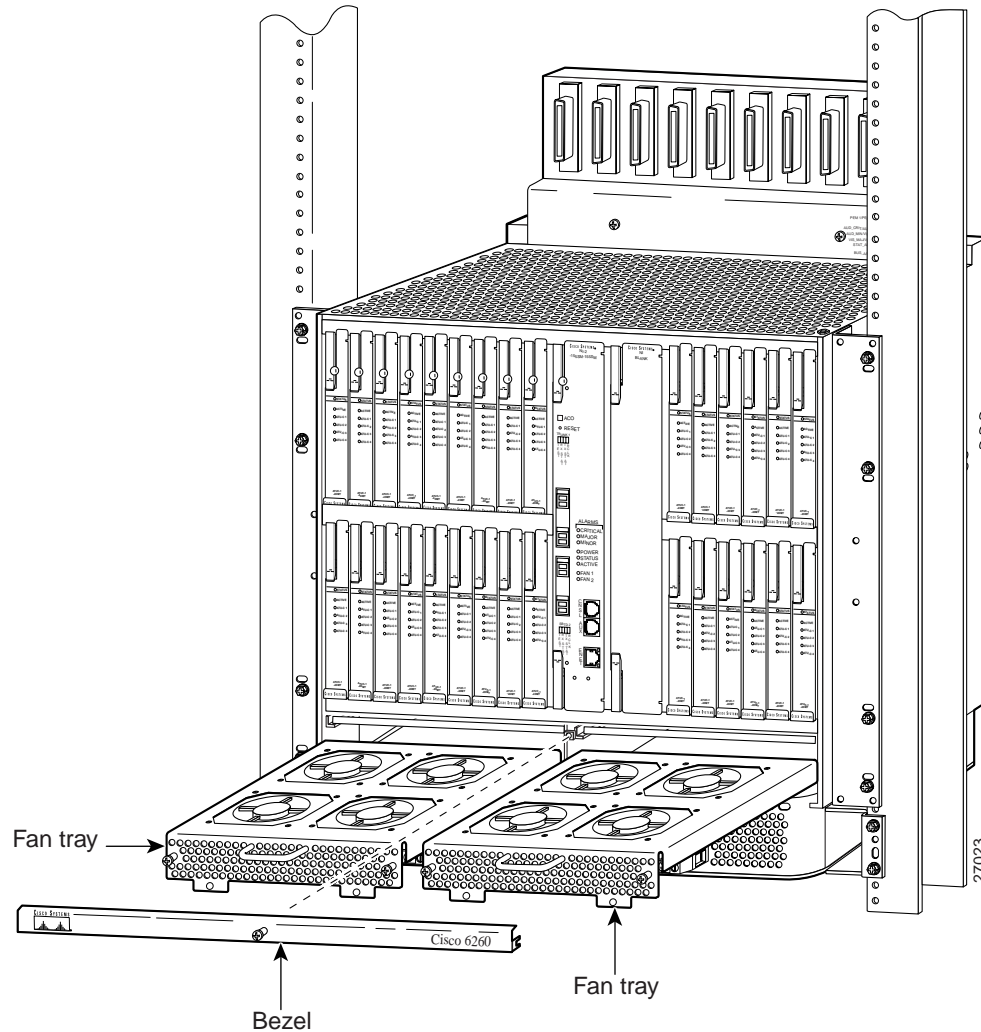

- Step 4** Press the fan tray firmly into its slot to ensure that the power connectors mate. If the power is on, you will hear the fans start to turn. The fault light for the fan tray you are installing will stay on until the fans reach full speed, which takes several seconds. (Fan fault LEDs are Fan 1 and Fan 2 on the NI-2 card, and Fan Tray 1 and Fan Tray 2 on the PEM.)



Note When you insert a fan tray, you might hear the fans in the other fan tray slow down; this is normal.

- Step 5** Use the Phillips-head screwdriver to tighten the two fasteners on the fan tray.
- Step 6** Replace the bezel, and use a Phillips-head screwdriver to tighten the screw and secure the bezel.
- Step 7** Verify that the fan tray LEDs on the PEM are solid green once the module is installed and secured. If the LEDs are not green, refer to the *Cisco 6260 Hardware Installation Guide* for troubleshooting procedures.

Fan Tray Maintenance

The following section describes the preventive maintenance procedures for the fan tray.

Replacing or Cleaning the Air Filter

You must periodically clean or replace the two air filters in the Cisco 6260.

Once a month (or more often in dusty environments), examine the air filters and clean or replace them if they are dirty. Keep a log recording the date of each filter cleaning and filter replacement.

You can clean or replace the air filters while the Cisco 6260 remains powered up and fully operational. You can order a replacement air filter (part number FILTER-6260=) through Cisco.

The remainder of this section explains how to remove, clean, and replace the filters.

Required Tools and Equipment

To clean the air filters, you need one of the following:

- Vacuum cleaner (preferred)
- Clean water
- Mild detergent, if the filter is very dirty

New air filters (product number FILTER-6260=) are the only parts you need if you decide that the old filters need replacing.

Removing an Air Filter

Complete the following steps to remove an air filter from the Cisco 6260 chassis. Perform this procedure for each of the two air filters in each chassis.

-
- Step 1** Connect a grounding strap to the ESD grounding jack that is located on the top right of the Cisco 6260 chassis card cage.
 - Step 2** Using a Phillips-head screwdriver, unscrew the screw and remove the metal bezel that covers the air filters. (See [Figure 5](#).)

Figure 5 Removing the Bezel and Air Filters

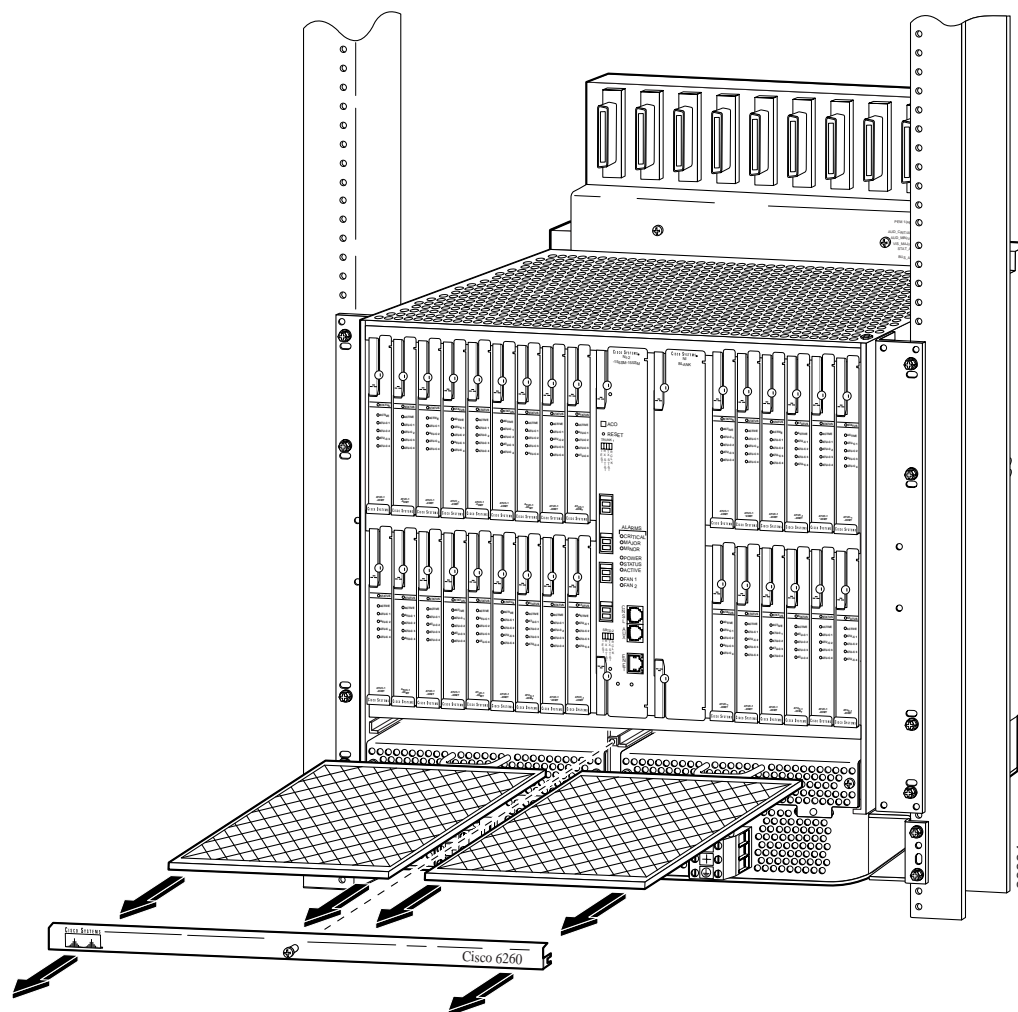

- Step 3** The air filter slides out from the top of the fan tray. Gently pull the filter toward you to remove it from the tray.
- Step 4** If you are replacing the air filter, discard it and go to the [“Replacing the Air Filter”](#) section on page 14.
- Step 5** If you wish to clean the air filter, go to the [“Cleaning the Air Filter”](#) section on page 13.

Cleaning the Air Filter

This section tells you how to clean a Cisco 6260 air filter. Go to the [“Replacing the Air Filter”](#) section on page 14 if you are replacing an old filter with a new one.

Use one of the following methods to clean the air filter:

- Vacuum. Vacuum cleaning is preferred because you need not dry the filter afterwards. Vacuum the filter until it is clean and free of dust.
- Clean with plain water. Placing the filter under a stream of plain water is equally effective. Hold the filter under the water with the metal grill facing up and let the water flow down through the filter. (This orientation causes the water to flow through the filter in the direction opposite from the usual air flow, so you dislodge rather than embed matter trapped in the filter.) Allow the filter to dry thoroughly before reinstalling it.
- Clean with hot water and mild detergent. If the filter is too dirty to be completely cleaned with a vacuum or with plain water, immerse the filter in a solution of hot water and mild detergent. Rinse the filter thoroughly in clear water and allow it to dry completely before reinstalling it.

Replacing the Air Filter

Complete the following steps to replace the air filter:

-
- Step 1** Connect a grounding strap to the ESD grounding jack that is located on the top right of the Cisco 6260 chassis card cage.
- Step 2** Hold the air filter so that
- The side with the metal grill is facing up.
 - One of the long sides goes in first.
- Step 3** Slide the filter into its slot above the fan tray.
- Step 4** Replace the bezel, and use a Phillips-head screwdriver to tighten the screw and secure the bezel.
-

Standards and Certifications

The fan tray has the same standards as the Cisco 6260 system, as shown in [Table 3](#).

Table 3 Regulatory Compliance for Cisco 6260 Hardware

| Area of Compliance | Compliance Standard |
|--------------------|--|
| Product Safety | UL 1950, 3rd Edition, EN 60950, AS/NZS 3260, IEC 950, FCC Part 15, Class B |
| Emissions | CISPR22, EN55022, AS/ANS 3548, ICES-003, VCCI, BSMI (CNS 13438) |
| Immunity | EN61000-4-2, 3, 4, 5 and 6 / IEC-61000-4-2, 3, 4, 5 and 6; EN61000-4-11 / IEC-61000-4-11 |
| Telecom | CTR 24 |
| ETSI | 300-386.1, 300-386.2 |

Related Documentation

A complete list of all DSL product related documentation is available on the World Wide Web at http://www.cisco.com/univercd/cc/td/doc/product/dsl_prod/index.htm.

Obtaining Documentation

The following sections provide sources for obtaining documentation from Cisco Systems.

World Wide Web

You can access the most current Cisco documentation on the World Wide Web at the following sites:

- <http://www.cisco.com>
- <http://www-china.cisco.com>
- <http://www-europe.cisco.com>

Documentation CD-ROM

Cisco documentation and additional literature are available in a CD-ROM package, which ships with your product. The Documentation CD-ROM is updated monthly and may be more current than printed documentation. The CD-ROM package is available as a single unit or as an annual subscription.

Ordering Documentation

Cisco documentation is available in the following ways:

- Registered Cisco Direct Customers can order Cisco Product documentation from the Networking Products MarketPlace:
http://www.cisco.com/cgi-bin/order/order_root.pl
- Registered Cisco.com users can order the Documentation CD-ROM through the online Subscription Store:
<http://www.cisco.com/go/subscription>
- Nonregistered CCO users can order documentation through a local account representative by calling Cisco corporate headquarters (California, USA) at 408 526-7208 or, in North America, by calling 800 553-NETS(6387).

Documentation Feedback

If you are reading Cisco product documentation on the World Wide Web, you can submit technical comments electronically. Click Feedback in the toolbar and select Documentation. After you complete the form, click Submit to send it to Cisco.

You can e-mail your comments to bug-doc@cisco.com.

To submit your comments by mail, for your convenience many documents contain a response card behind the front cover. Otherwise, you can mail your comments to the following address:

Cisco Systems, Inc.
Document Resource Connection
170 West Tasman Drive
San Jose, CA 95134-9883

We appreciate your comments.

Obtaining Technical Assistance

Cisco provides Cisco.com as a starting point for all technical assistance. Customers and partners can obtain documentation, troubleshooting tips, and sample configurations from online tools. For Cisco.com registered users, additional troubleshooting tools are available from the TAC website.

Cisco.com

Cisco.com is the foundation of a suite of interactive, networked services that provides immediate, open access to Cisco information and resources at anytime, from anywhere in the world. This highly integrated Internet application is a powerful, easy-to-use tool for doing business with Cisco.

Cisco.com provides a broad range of features and services to help customers and partners streamline business processes and improve productivity. Through Cisco.com, you can find information about Cisco and our networking solutions, services, and programs. In addition, you can resolve technical issues with online technical support, download and test software packages, and order Cisco learning materials and merchandise. Valuable online skill assessment, training, and certification programs are also available.

Customers and partners can self-register on Cisco.com to obtain additional personalized information and services. Registered users can order products, check on the status of an order, access technical support, and view benefits specific to their relationships with Cisco.

To access Cisco.com, go to the following website:

<http://www.cisco.com>

Technical Assistance Center

The Cisco TAC website is available to all customers who need technical assistance with a Cisco product or technology that is under warranty or covered by a maintenance contract.

Contacting TAC by Using the Cisco TAC Website

If you have a priority level 3 (P3) or priority level 4 (P4) problem, contact TAC by going to the TAC website:

<http://www.cisco.com/tac>

P3 and P4 level problems are defined as follows:

- P3—Your network performance is degraded. Network functionality is noticeably impaired, but most business operations continue.
- P4—You need information or assistance on Cisco product capabilities, product installation, or basic product configuration.

In each of the above cases, use the Cisco TAC website to quickly find answers to your questions.

To register for Cisco.com, go to the following website:

<http://www.cisco.com/register/>

If you cannot resolve your technical issue by using the TAC online resources, Cisco.com registered users can open a case online by using the TAC Case Open tool at the following website:

<http://www.cisco.com/tac/caseopen>

Contacting TAC by Telephone

If you have a priority level 1 (P1) or priority level 2 (P2) problem, contact TAC by telephone and immediately open a case. To obtain a directory of toll-free numbers for your country, go to the following website:

<http://www.cisco.com/warp/public/687/Directory/DirTAC.shtml>

P1 and P2 level problems are defined as follows:

- P1—Your production network is down, causing a critical impact to business operations if service is not restored quickly. No workaround is available.
- P2—Your production network is severely degraded, affecting significant aspects of your business operations. No workaround is available.

This document is to be used in conjunction with the documents listed in the “Related Documentation” section.

AccessPath, AtmDirector, Browse with Me, CCDA, CCDE, CCDP, CCIE, CCNA, CCNP, CCSI, CD-PAC, *CiscoLink*, the Cisco NetWorks logo, the Cisco Powered Network logo, Cisco Systems Networking Academy, the Cisco Systems Networking Academy logo, Discover All That’s Possible, Fast Step, Follow Me Browsing, FormShare, FrameShare, GigaStack, IGX, Internet Quotient, IP/VC, iQ Breakthrough, iQ Expertise, iQ FastTrack, the iQ Logo, iQ Net Readiness Scorecard, MGX, the Networkers logo, *Packet*, PIX, RateMUX, ScriptBuilder, ScriptShare, SlideCast, SMARTnet, TransPath, Voice LAN, Wavelength Router, WebViewer are trademarks of Cisco Systems, Inc.; Changing the Way We Work, Live, Play, and Learn, Empowering the Internet Generation, are service marks of Cisco Systems, Inc.; and Aironet, ASIST, BPX, Catalyst, Cisco, the Cisco Certified Internetwork Expert logo, Cisco IOS, the Cisco IOS logo, Cisco Systems, Cisco Systems Capital, the Cisco Systems logo, Enterprise/Solver, EtherChannel, EtherSwitch, FastHub, FastSwitch, IOS, IP/TV, LightStream, MICA, Network Registrar, Post-Routing, Pre-Routing, Registrar, StrataView Plus, Stratm, SwitchProbe, TeleRouter, and VCO are registered trademarks of Cisco Systems, Inc. or its affiliates in the U.S. and certain other countries.

All other brands, names, or trademarks mentioned in this document or Web site are the property of their respective owners. The use of the word partner does not imply a partnership relationship between Cisco and any other company. (0101R)

Copyright © 2001, Cisco Systems, Inc.
All rights reserved.

