

Overview

This chapter introduces the Cisco 1400 series router and covers the following topics:

- Key Features
- Technology Overview
- Rear-Panel Ports and LEDs
- Front-Panel LEDs
- Router Memory
- Unpacking the Router
- Additional Required Equipment

The Cisco 1400 series routers are a family of ATM-25 and ADSL routers that connect small businesses and remote branch offices to the Internet or to larger, corporate networks.

Note For definitions of the terms and acronyms used in this chapter, refer to the “Terms” section on page 1-3 of this chapter.

Table 1-1 describes the Cisco 1400 series routers and Figure 1-1 and Figure 1-2 illustrate the router rear panels.

Table 1-1 Cisco 1400 Series Router Model Comparison

Cisco 1401	Cisco 1407	Cisco 1417
<ul style="list-style-type: none"> • One 10BaseT interface • One ATM-25 interface for connection to an external, ATM 25-to-DSL modem, providing an ADSL connection of up to 8 Mbps to the Internet or to corporate networks 	<ul style="list-style-type: none"> • One 10BaseT interface. • One standard ADSL DMT (Issue 2) interface that supports an ATM-cell-based ADSL connection of up to 8 Mbps to the Internet or to a corporate network • Analog Devices Incorporated ADSL chip-set • Cisco 6100 and Cisco 6200E DSLAM compatibility. 	<ul style="list-style-type: none"> • One 10BaseT interface • One standard ADSL DMT (Issue 2) interface that supports an ATM-cell-based ADSL connection of up to 8 Mbps to the Internet or to a corporate network • Alcatel ADSL chip-set • Alcatel ASAM compatibility

Figure 1-1 Cisco 1401 Router Rear Panel

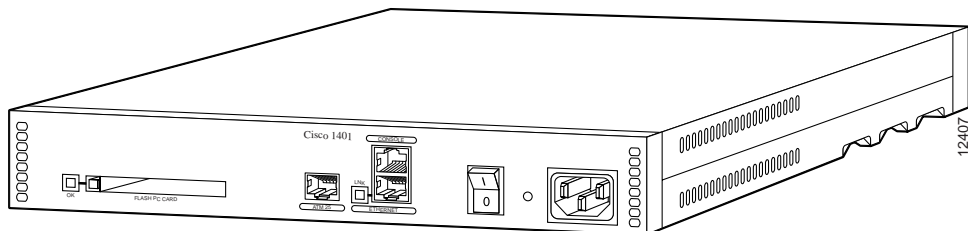
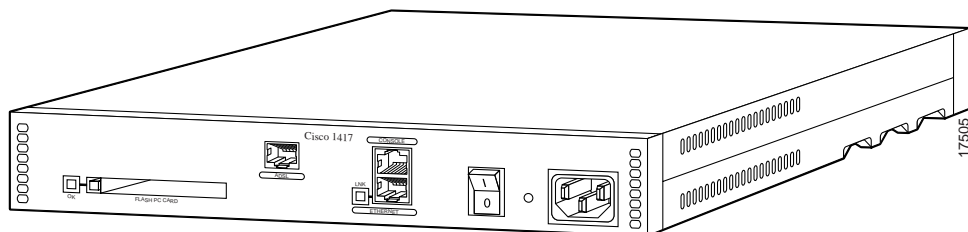

Figure 1-2 Cisco 1407 and Cisco 1417 Router Rear Panel



Key Features

Following are the key features of the Cisco 1400 series routers:

- Ethernet port—For connecting to a 10BaseT LAN through an Ethernet hub or switch.
- ATM-25 port (Cisco 1401 router)—For connecting through a DSL modem over an ADSL line to a central service provider.
- ADSL port (Cisco 1407 and Cisco 1417 routers)—For connecting directly over an ADSL line to a central service provider.
- Console port—For connecting a terminal or PC to configure and manage the router. Supports up to 9600 bps (up to 115.2 kbps for software download).
- Supports IP, IPX, PPP over ATM, and firewall security.
- Supports ATM features such as ATM Adaption Layer 5, ATM PVCs, and RFC 1483.
- Supports SNMP for management over an SNMP network.
- Supports Cisco ATM Management Information Base (MIB).

<<Reviewers: Do we need to add more features here for the latest SW releases?>>

Terms

These are some key ADSL elements and terms you should know:

- Asymmetric Digital Subscriber Line (ADSL)—One of several kinds of digital subscriber line (DSL) technologies that together are referred to as xDSL. ADSL is made up of three channels:
 - High-speed (up to 8 Mbps) downstream data channel
 - Lower-speed (up to 1 Mbps) upstream data channel
 - Standard telephone service channel
- ATM subscriber access multiplexer (ASAM)—A telephone central office multiplexer that supports ADSL ports over a wide range of network interfaces. An ASAM sends and receives subscriber data (often Internet services) over existing copper telephone lines,

concentrating all traffic onto a single high-speed trunk for transport to the Internet or the enterprise intranet. A device similar to a DSLAM; different manufacturers use different terms for similar devices.

- Asynchronous Transfer Mode (ATM)—A connection-oriented data transfer mode that segments data into fixed cell-lengths (53 bytes), transports the cells, and reassembles them at the destination. ATM does not limit how fast data can be transferred over a connection. The fixed-cell-size feature enables ATM to send any type of data efficiently.
- Protocol: ATM, any AAL, 25-, 155- or 622-Mbps internal ATM multiplexing bus.
- Digital subscriber line access multiplexer (DSLAM)—A telephone central office multiplexer, such as the Cisco 6200, that supports ADSL ports over a wide range of network interfaces. A DSLAM sends and receives subscriber data (often Internet services) over existing copper telephone lines, concentrating all traffic onto a single high-speed trunk for transport to the Internet or the enterprise intranet. A device similar to an ASAM; different manufacturers use different terms for similar devices.
- Discrete Multi-Tone (DMT)—The American National Standards Institute (ANSI)-specified method of data signal modulation for ADSL.
- Internet service provider (ISP)—A company that provides other companies or individuals with access to, or presence on, the Internet.
- Microfilter—A device that prevents certain router frequencies from travelling over the telephone line and interfering with telephone calls. For information on the type of microfilter to use with your router, contact your service provider or Cisco reseller.
- Point-to-Point Protocol (PPP)—A protocol that transfers data over a WAN using bidirectional synchronous or asynchronous connections between two endpoints. PPP controls the call setup between the Cisco 1400 series router and the remote device. PPP enables the Cisco 1400 series router to multiplex various protocols over individual virtual connections. IP and IPX packets can be sent over PPP with ATM establishing the connection between the two devices.
- Permanent virtual connection (PVC)—ATM requires that a circuit (or connection) is established that will pass data between the two devices. This connection is not a physical connection but a logical or virtual connection.

The Cisco 1400 series router supports PVCs to establish an end-to-end connection to the remote device. The router does not support switched virtual connections (SVCs).

- “Plain old telephone service” (POTS)—Basic telephone service.
- POTS splitter—A device (or one part of a larger device) that enables both an ADSL data device (for example, a Cisco 1400 series router) and a standard analog device (such as a telephone) to share the same ADSL line. For information on the type of POTS splitter to use with your router, contact your service provider or Cisco reseller.
- SNMP—Simple Network Management Protocol

Technology Overview

An ADSL line is a DSL that transfers data from the telephone central office to the user much faster than the user sends data to the telephone central office. ADSL is ideal for applications such as high-speed Internet access and video-on-demand, in which the server sends much more data than the client sends. Internet users, in general, download more information from the Internet than they upload.

One of the key features of ADSL is that it operates over existing standard telephone wires, enabling simultaneous voice and data transmissions over the same telephone line.

ATM over ADSL

The Cisco 1400 series routers use ATM over ADSL to transfer data to and from remote networks, such as an ISP or corporate network.

By using ATM, the router can maintain a communication session with the remote location until the session ends. A continuous connection results in a higher quality of service than that of many other data protocols.

Network Example

Figure 1-3 illustrates a network that includes a Cisco 1400 series router.

A Cisco 1401 router connects to the ADSL line through a DSL modem. (The Cisco 1407 and Cisco 1417 routers do not require the modem.) Some DSL modems have an integrated POTS splitter, which connects a phone or fax machine to the same ADSL line as the router.

If you are using a telephone and the Cisco 1407 or Cisco 1417 router on the same telephone line, an external POTS splitter is required for optimal performance. A splitter reduces possible interference on both data connections and voice calls, which use different frequencies. For more information, refer to the “Using POTS Splitters and Microfilters” section in the “Installation” chapter later in this guide.

Figure 1-3 Network with the Cisco 1400 Series Router

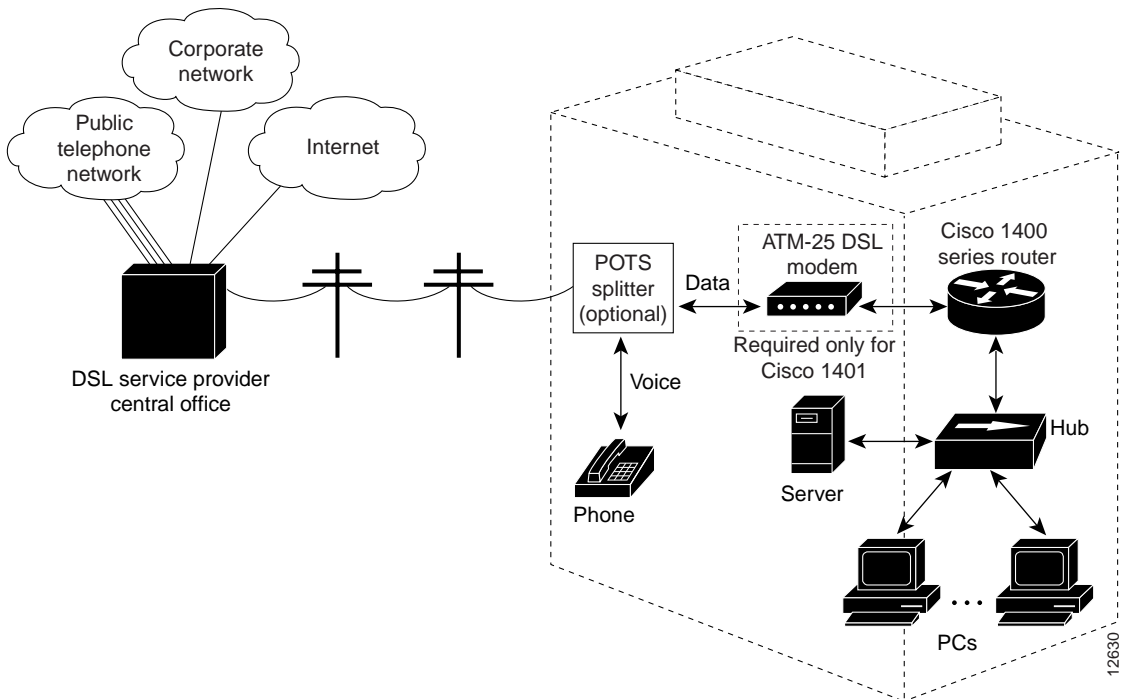

Rear-Panel Ports and LEDs

Figure 1-4 and Figure 1-5 illustrate the ports and LEDs on the rear panel of the Cisco 1400 series routers. Table 1-2 describes the rear-panel port functions, and Table 1-3 describes the LEDs.

Figure 1-4 Cisco 1401 Rear-Panel Ports and LEDs

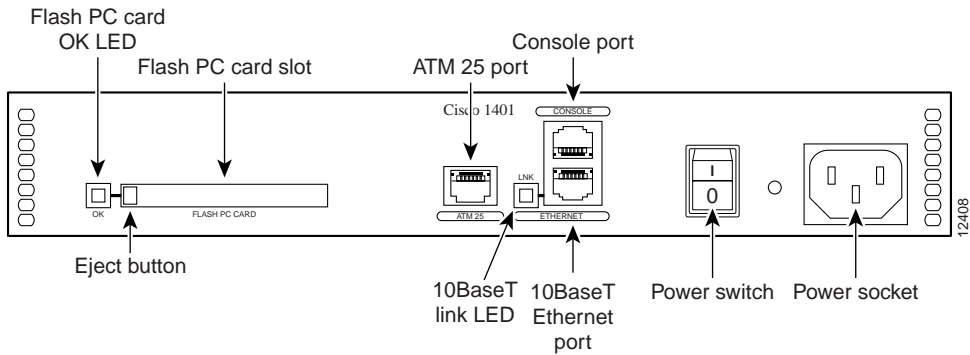
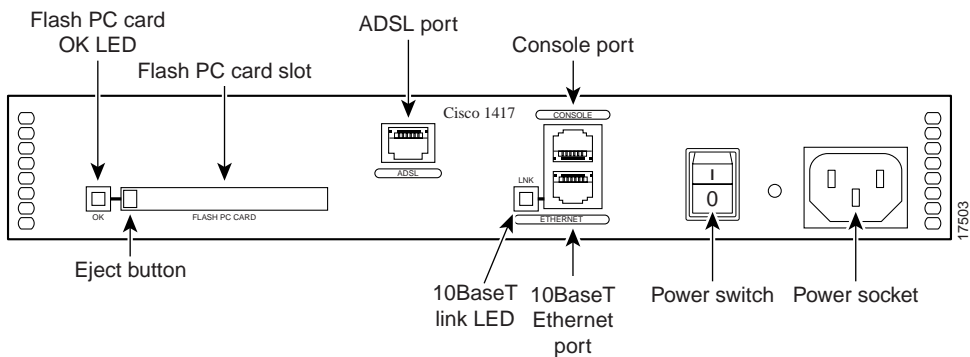

Figure 1-5 Cisco 1407 and Cisco 1417 Rear-Panel Ports and LEDs



Rear-Panel Ports and LEDs

Table 1-2 Rear-Panel Ports

Port	Label/Color	Description
Ethernet port	ETHERNET (yellow)	Connects the router to the local 10BaseT Ethernet network.
ATM (Cisco 1401 router)	ATM 25 (green)	Connects the router to the DSL modem. The DSL modem connects the router to the ADSL line.
ADSL (Cisco 1407 and Cisco 1417 router)	ADSL (purple)	Connects the router directly to an ADSL line or to an ADSL line through a POTS splitter. The POTS splitter enables the router and a telephone to share the ADSL line.
Console port	CONSOLE (blue)	Connects the router to a terminal, terminal server, or PC for software configuration.
Flash PC card slot	FLASH PC CARD	If not already installed, insert the Flash PC card into this slot.
Power socket	Input: 100-240 VAC~ Freq: 50/60 Hz Current 1.2-0.6 A 1,2-0,6 A Watts: 40W	Connects the router to the power supply.

Table 1-3 Rear-Panel LEDs

LED Label	Color	Description
OK	Green	On means that the Flash memory card is correctly inserted in the Flash PC card slot.
LNK	Green	On means that the router is connected to the Ethernet LAN through the 10BaseT Ethernet port.

Front-Panel LEDs

Use the front-panel LEDs to determine network activity and status on the Ethernet port and the WAN port. Figure 1-6 illustrates these LEDs, and Table 1-4 describes them.

Figure 1-6 Front-Panel LEDs

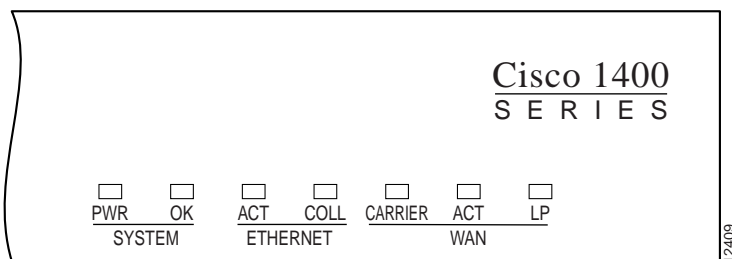

Table 1-4 Front-Panel LEDs

LED Label	Color	Description
SYSTEM		
PWR	Green	On when DC power is being supplied to the router.
OK	Green	On when the router has successfully booted up and the software is functional. This LED blinks during the power-on self-test (POST).
ETHERNET		
ACT	Green	Blinks when there is network activity on the Ethernet LAN.
COLL	Yellow	Blinks when there are network (packet) collisions on the Ethernet LAN.
WAN		
CARRIER	Green	On steady when the router has synchronized with the equipment connected to the ATM-25 port (Cisco 1401 router) or the ADSL equipment at the service provider office (Cisco 1407 and Cisco 1417 routers).
ACT	Green	Blinks when data is being sent to or received from the ATM-25 port (Cisco 1401 router) or the ADSL port (Cisco 1407 and Cisco 1417 routers).
LP	Yellow	On steady when the ATM-25 port (Cisco 1401 router) or the ADSL port (Cisco 1407 and Cisco 1417 routers) is in loopback mode.

Router Memory

This section describes the types of memory used by the router and how to find out how much of each type the router is using.

Memory Types

The Cisco 1400 series routers have the following types of memory:

- Dynamic RAM (DRAM)—This is the main storage memory for the router. DRAM is also called *working storage* and contains the dynamic configuration information. The Cisco 1400 series router operates from DRAM.
- Nonvolatile RAM (NVRAM)—This type of memory contains a backup copy of your configuration. If the power is lost or the router is turned off, this backup copy enables the router to return to operation without reconfiguration.
- Flash memory—This special kind of erasable, programmable ROM contains a copy of the Cisco IOS software. The Flash memory structure can store multiple copies of the Cisco IOS software. You can load a new level of the operating system in every router in your network and then, when convenient, upgrade the whole network to the new level. The Flash memory on the Cisco 1400 series router is stored on a Flash PC card.

Displaying Memory Amounts

Use the **show version** command to view the amount of NVRAM, DRAM, and Flash memory stored in your router. Below is an example of the **show version** command. The command output in bold text displays the memory amounts for this router.

```
1401# show version
Cisco Internetwork Operating System Software
IOS (tm) 1400 Software (C1400-NSY-M),Version 12.0(19980714:220727)
Copyright (c) 1986-1998 by cisco Systems, Inc.
Compiled Wed 15-Jul-98 10:56 by cisco
Image text-base: 0x02005000, data-base: 0x024E9ECC
.
.
.
cisco 1401 (68360) processor (revision A) with 9216K/3072K bytes of
memory.
Processor board ID 04618030, with hardware revision 00000000
Bridging software.
X.25 software, Version 3.0.0.
1 Ethernet/IEEE 802.3 interface(s)
1 ATM network interface(s)
System/IO memory with parity disabled
8192K bytes of DRAM onboard 4096K bytes of DRAM on SIMM
System running from RAM
8K bytes of non-volatile configuration memory.
4096K bytes of processor board PCMCIA flash (Read/Write)

Configuration register is 0x2
```

Unpacking the Router

Figure 1-7 shows the items that come in the router accessory kit. Contact your Cisco reseller if anything is missing from your accessory kit.

Figure 1-7 Router Box Contents

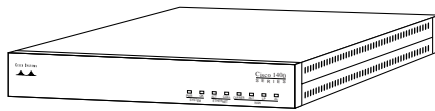

Cisco 1400 router

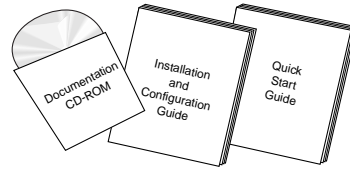

Product documentation

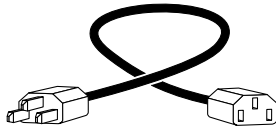

Power cord (black)

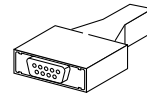

DB-9 to RJ-45 console adapter

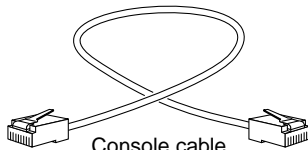

Console cable
(light blue, RJ-45 to RJ-45)

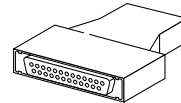

DB-25 to RJ-45 console adapter

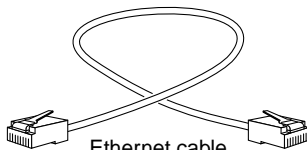

Ethernet cable
(yellow, RJ-45 to RJ-45)



ATM 25 cable
(green, RJ-45 to RJ-45)
(Cisco 1401 router)



ADSL cable
(purple RJ-11 to RJ-11)
(Cisco 1407 and Cisco 1417 routers)

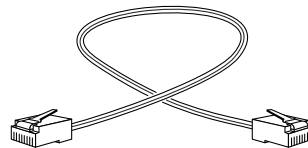

POTS crossover cable (if ordered)
(purple with blue stripe, RJ-11 to RJ-11)

12410

Additional Required Equipment

Table 1-5 is a list of other equipment that you need to completely install your router.

Table 1-5 Additional Required Equipment

Equipment	When You Use It
10BaseT Ethernet hub or 10BaseT Ethernet switch	Hubs and switches connect multiple pieces of network equipment (including the Cisco 1400 series router) to create a network. You need either a hub or switch, not both, to connect your router to the LAN.
ATM-DSL modem (Cisco 1401 router)	An ATM-DSL modem (for example, a Cisco 625 or Cisco 626) connects ATM-based devices (such as the Cisco 1401 router) to ADSL lines. Some DSL modems include an integrated POTS splitter, which connects the router and a telephone or fax machine to the same ADSL line. If you are not sure what type of DSL modem to use with your router, contact your ADSL service provider or your Cisco reseller.
RJ-11-to-RJ-11 cable (Cisco 1401 router only)	This cable connects a DSL modem (used with the Cisco 1401 router) to the ADSL line. You might need to provide one if it is not included with the modem.
POTS splitter (Cisco 1407 and Cisco 1417 routers)	Optimal router and telephone performance (when the router and telephone are used on the same telephone line) requires a POTS splitter. A splitter reduces interference that might occur on data connections and voice calls. Some types of splitters can be used to connect analog devices, such as a telephone or fax machine, to the same ADSL line as the router. For more information, refer to the “Using POTS Splitters and Microfilters” section in the “Installation” later in this guide. If you are not sure what type of splitter to use, contact your service provider or your Cisco reseller.
Microfilter(s) (Cisco 1407 and Cisco 1417 routers)	Microfilters can be used (in addition to a POTS splitter) to further reduce interference on a voice call. Refer to the “Using POTS Splitters and Microfilters” section in the “Installation” later in this guide for detailed information on when to use microfilters with the Cisco 1417 router. If you are not sure what type of microfilter to use, contact your service provider or your Cisco reseller.

Additional Required Equipment
