



# Quad-Port DMT-2 ATU-C Line Card FRU Installation and Configuration Notes

---

**Product Number:** ATUC-1-4DMT(=)

This document provides information about installing and replacing the quad-port Discrete Multitone-Issue 2 (DMT-2) asymmetric digital subscriber line (ADSL) Transmission Unit—central office (ATU-C) line card. The quad-port DMT-2 ATU-C line card (4xDMT-2) is a field-replaceable unit (FRU) for the following chassis:

- Cisco 6130 with NI-2
- Cisco 6260

## Contents

This document includes the following sections:

- Introduction, page 2
- Installation Prerequisites, page 5
- General Safety Precaution and Maintenance Guidelines, page 6
- Removing a 4xDMT-2, page 10
- Installing or Replacing a 4xDMT-2, page 10
- Traffic Handling, page 12
- Standards and Certifications, page 12
- Related Documentation, page 12
- Obtaining Documentation, page 12
- Obtaining Technical Assistance, page 13

# Introduction

The 4xDMT-2 is compatible with the Cisco 6130 with NI-2 and the Cisco 6260 chassis and is designed for use in one of the following configurations:

- Direct Connect with a POTS splitter chassis—Provisions one modem directly and is physically connected to one specific subscriber line through the POTS splitter chassis.
- Direct Connect without a POTS splitter chassis—Provisions one modem directly and is physically connected to one specific subscriber line through the main distribution frame (MDF) connections.

The 4xDMT-2

- Is T1.413 Issue 2 compliant.
- Supports four ADSL modem connections.
- Converts ADSL modulation from the line into digital data streams to and from the NI-2 card.
- Negotiates the line rate with the CPE when it trains and bases the rate on line quality and distance.
- Has top and bottom locking levers with top and bottom locking tabs.

If provisioned, the 4xDMT-2 rate adapts to the maximum bit rate negotiable on the line. The maximum bit rate settings are provisioned in the management software.

The Cisco 6130 chassis can include up to 32 4xDMT-2s for a total of 128 ADSL modem connections.

## Quad-Port DMT-2 ATU-C Line Card Faceplate

Figure 1 shows a close-up of the 4xDMT-2 faceplate.

**Figure 1** Quad-port DMT-2 ATU-C Line Card Faceplate

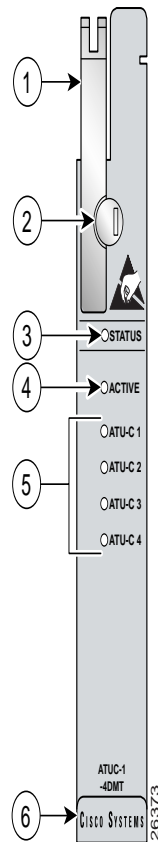

## Quad-Port DMT-2 ATU-C Line Card LED Indicators

Table 1 describes LEDs on the 4xDMT-2.

**Table 1** Quad-port DMT-2 ATU-C Line Card LEDs

LED	State	Function
STATUS	Green slow blinking	No errors, but no connection established.
	Green solid	The image download is in progress.
	Red	NI-2 communication established.
	Off	The self-test or line card has failed. The ATU-C line card has a power failure.
ACTIVE	Green solid	The line card is activated.
	Off	The line card is not in service.

**Table 1 Quad-port DMT-2 ATU-C Line Card LEDs (continued)**

LED	State	Function
ATU-C 1	Green solid Green blinking Off	Modem 1 is trained. Training is in progress for modem 1. Modem 1 is idle.
ATU-C 2	Green solid Green blinking Off	Modem 2 is trained. Training is in progress for modem 2. Modem 2 is idle.
ATU-C 3	Green solid Green blinking Off	Modem 2 is trained. Training is in progress for modem 2. Modem 2 is idle.
ATU-C 4	Green solid Green blinking Off	Modem 2 is trained. Training is in progress for modem 2. Modem 2 is idle.

## Quad-Port DMT-2 ATU-C Line Card Block Diagram

Figure 2 is a block diagram of the 4xDMT-2.

**Figure 2 Quad-Port DMT-2 ATU-C Line Card Block Diagram**

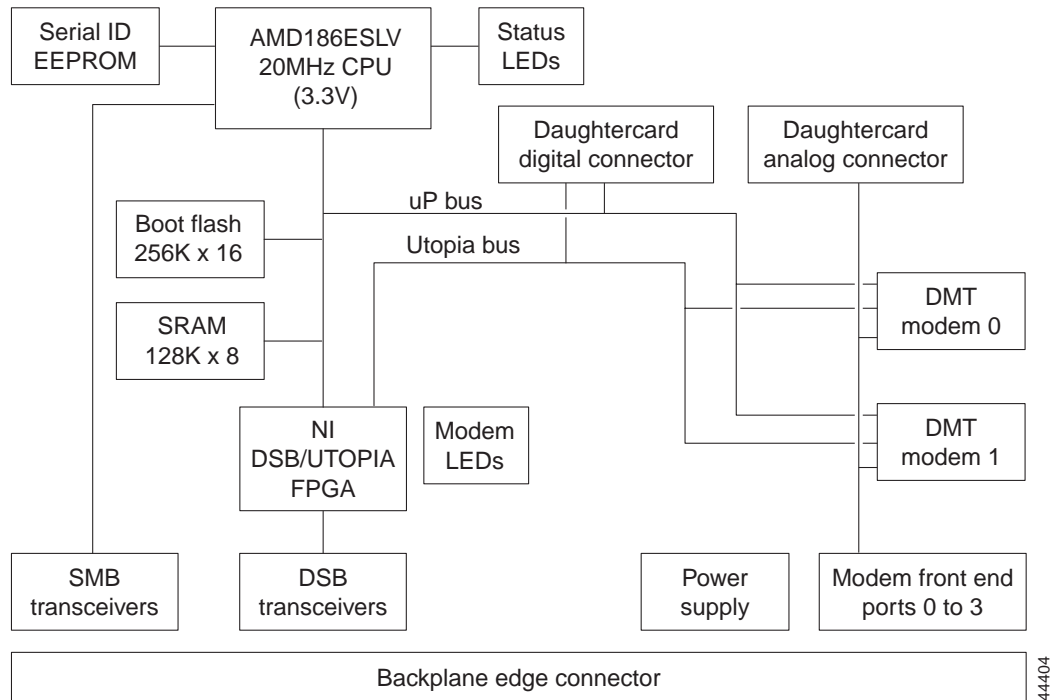

## Slot Configuration

In the Cisco 6130 chassis with NI-2, you must install the line cards in slots 1 through 8, 13 through 28, and 31 through 38, as shown in Figure 3. In the Cisco 6260 chassis, you must install the line cards in slots 1 to 9 or 12 to 32.

**Figure 3** Quad-port DMT-2 Slot Configuration for the Cisco 6130 with NI-2 Chassis

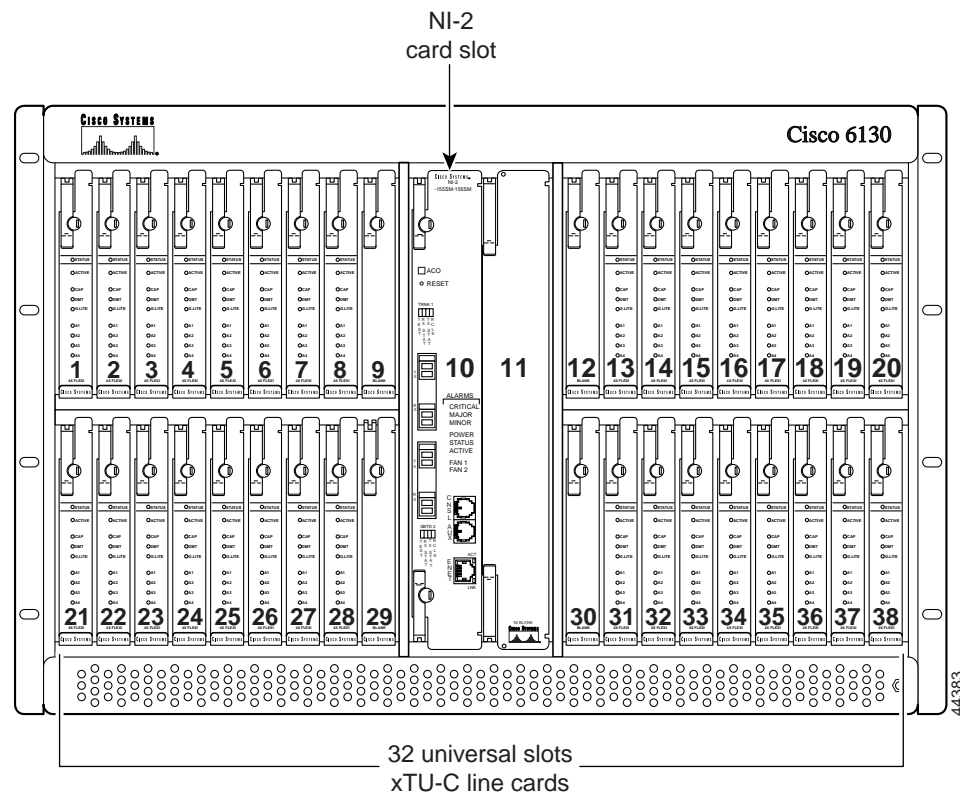

## Installation Prerequisites

This section describes software requirements and lists the parts and tools that you need to install the 4xDMT-2.

### Software Requirements

Table 2 lists the Cisco IOS release that is recommended for configuring and managing the 4xDMT-2 with the Cisco 6130 with NI-2 and the Cisco 6260.

*Table 2 Quad-port DMT-2 ATU-C Line Card Software Requirements*

Hardware Platform	Recommended Minimum Cisco IOS Release
Cisco 6130 NI-2 DSLAM	Cisco IOS Release 12.0(5) DA CDM Release 3.2
Cisco 6260	Cisco IOS Release 12.0(5) DA CDM Release 3.0

## Part and Tool Requirements

To install or replace the 4xDMT-2 line card, you need the following parts and tools:

- 4xDMT-2.
- Necessary equipment for ESD protection—Required whenever you handle Cisco DSLAM equipment, which includes the chassis, line cards, and cards.
- Flat-head screwdriver.



**Note**

The system has no internal user-serviceable parts. However, you can add or remove a 4xDMT-2 without removing power from the system (hot swapping).

## General Safety Precaution and Maintenance Guidelines

This section describes the following concepts:

- General Safety Precautions
- Hot Swapping Line Cards
- Line Card Installation and Replacement Suggestions

### General Safety Precautions

Before working on the equipment, be aware of standard safety practices and the hazards involved in working with electrical circuitry to prevent accidents. Adhere to the following cautions and warnings for safe and hazard-free installation.



**Note**

To see translations of the warnings that appear in this publication, refer to the *Regulatory Compliance and Safety Information for the Cisco 6100 Series System* document.



**Tips**

In the following warnings, the terms *cover panel* and *safety cover* refer to the chassis front cover.

**Caution**

Proper ESD protection is required whenever you handle Cisco DSLAM equipment. Installation and maintenance personnel should be properly grounded using ground straps to eliminate the risk of ESD damage to the equipment. Line cards are subject to ESD damage whenever they are removed from the chassis.

**Caution**

Installing the line cards in the chassis with the power leads reversed can damage the line cards.

**Caution**

If you configure power connections improperly and apply power while the line cards are installed, the line card and chassis could be damaged.

**Warning**

**Use copper conductors only.**

**Warning**

**A readily accessible two-poled disconnect device must be incorporated in the fixed wiring.**

**Warning**

**Never install telephone wiring during an electrical storm.**

**Warning**

**Do not reach into a vacant slot or chassis while you install or remove a line card or a fan. Exposed circuitry could constitute an energy hazard.**

**Warning**

**Blank faceplates and cover panels serve three important functions: they prevent exposure to hazardous voltages and currents inside the chassis; they contain electromagnetic interference (EMI) that might disrupt other equipment; and they direct the flow of cooling air through the chassis. Do not operate the system unless all cards, faceplates, front covers, and rear covers are in place.**

**Warning**

**Only trained and qualified personnel should be allowed to install, replace, or service this equipment.**

**Warning**

**The power supply circuitry for the Cisco DSLAM equipment can constitute an energy hazard. Before you install or replace the equipment, remove all jewelry (including rings, necklaces, and watches). Metal objects can come into contact with exposed power supply wiring or circuitry inside the DSLAM equipment. This could cause the metal objects to heat up and cause serious burns or weld the metal object to the equipment.**



Warning

Do not work on the system or connect or disconnect cables during periods of lightning activity.



Warning

Use caution when installing or modifying telephone lines.



Warning

Metal objects heat up when connected to power and ground, and can cause serious burns.



Warning

Secure all power cabling when installing this unit to avoid disturbing field-wiring connections.



Warning

Ultimate disposal of this product should be handled according to all national laws and regulations.



Warning

This unit is intended for installation in restricted access areas. A restricted access area is where access can only be gained by service personnel through the use of a special tool, lock and key, or other means of security, and is controlled by the authority responsible for the location.



Warning

The safety cover is an integral part of the product. Do not operate the unit without the safety cover installed. Operating the unit without the cover in place will invalidate the safety approvals and pose a risk of fire and electrical hazards.



Warning

Connect the unit only to DC power source that complies with the Safety Extra-Low Voltage (SELV) requirements in IEC 60950 based safety standards.



Warning

This product requires short-circuit (overcurrent) protection, to be provided as part of the building installation. Install only in accordance with national and local wiring regulations.



Warning

Care must be given to connecting units to the supply circuit so that wiring is not overloaded.



Warning

Never install telephone jacks in wet locations unless the jack is specifically designed for wet locations.





Do not use a telephone to report a gas leak in the vicinity of the leak.



Avoid using a telephone (other than a cordless type) during an electrical storm. There may be a remote risk of electric shock from lightning.



Never touch uninsulated telephone wires or terminals unless the telephone line has been disconnected at the network interface.



Do not use this product near water; for example, near a bath tub, wash bowl, kitchen sink or laundry tub, in a wet basement, or near a swimming pool.

## Hot Swapping Line Cards

The 4xDMT-2 supports hot swapping. Hot swapping allows you to remove, replace, and rearrange the line cards without disconnecting the system power. When the system detects that a line card is added or removed, it automatically runs diagnostic and discovery routines, and acknowledges the presence or absence of the line card.

If you remove and replace a 4xDMT-2 with another 4xDMT-2, the newly installed line card receives the same provisioning as the original line card. The system resumes operation without any operator intervention.

If an unprovisioned line card is installed for the first time, the system identifies it as present but unprovisioned. Instructions for provisioning the line card are found in the appropriate software guide for your chassis.

## Line Card Installation and Replacement Suggestions

The following items are examples of recommended line card installation and replacement practices:

- Do not force the line card into its slot. This action can damage the pins on the backplane if they are not aligned properly with the line card.
- Ensure that the line card is straight and not at an angle when you install the line card in the slot. Installing the line card at an angle can damage the line card.
- Fully depress the ejector tabs to ensure that the line card connector mates with the backplane correctly. Firmly seat the line card in the slot.

Any line card that is only partially connected to the backplane can disrupt system operation.

# Removing a 4xDMT-2

Complete the following steps to remove a 4xDMT-2 from the chassis:

- Step 1** Open the front cover on the chassis, as necessary.
- Step 2** Use a flat-head screwdriver to move the locking tab from the locked to the unlocked position. Be sure to turn the locking tab so that it does not overlap the 4xDMT-2 as shown in Figure 4.

*Figure 4 Positioning the Locking Tab for the 4xDMT-2*

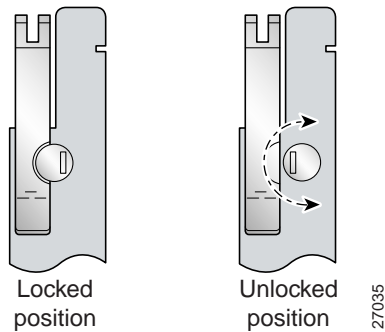

- Step 3** Lift up on the ejector tab. This action disconnects the line card from the backplane.
- Step 4** Carefully slide the line card out of the slot.

Either replace the line card that you remove, or insert a blank faceplate in the empty slot. See the “Installing or Replacing a 4xDMT-2” section on page 10 for 4xDMT-2 installation instructions. For blank faceplate installation instructions, refer to the appropriate hardware installation guide for your chassis.



**Note** Blank faceplates should occupy any empty slots in the chassis.

# Installing or Replacing a 4xDMT-2

Complete the following steps to install or replace the 4xDMT-2 in the chassis:



**Note** It is important that you complete each step before moving on to the next step.

- Step 1** Open the front cover on the chassis, as necessary.
- Step 2** Hold the 4xDMT-2 vertically, with the line card faceplate toward you and the connectors facing the chassis slot.
- Step 3** Align the upper and lower edges of the 4xDMT-2 with the upper and lower guides in the chassis slot.
- Step 4** Lift up on the ejector tab and gently apply pressure to the bottom of the faceplate while pushing the line card into the slot.

Figure 5 shows the line card installation for a Cisco 6130 with NI-2 chassis. The installation procedures will be the same for the Cisco 6260 chassis.

**Figure 5** Quad-port DMT-2 ATU-C Line Card Installation

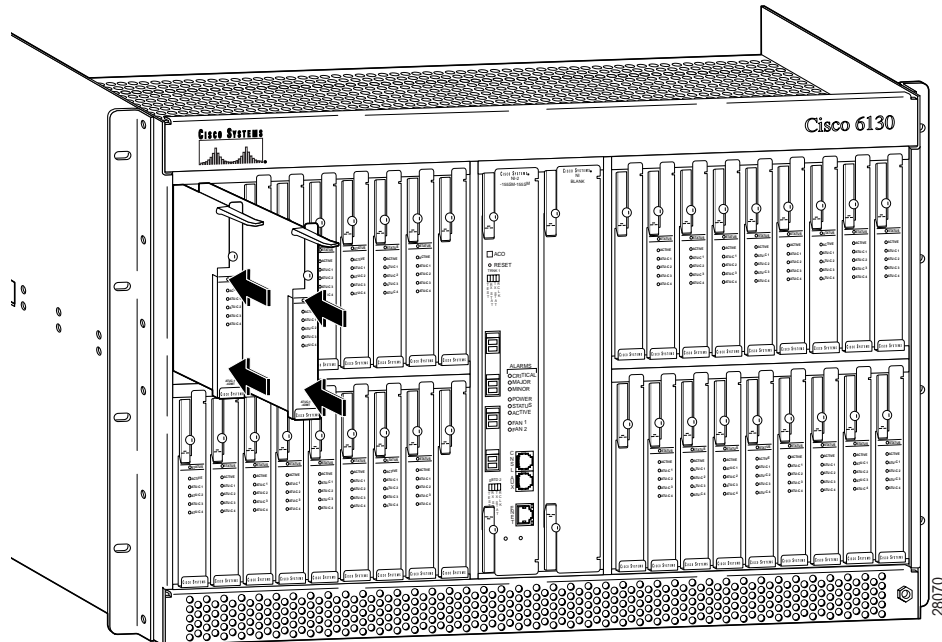

- Step 5** Push on the faceplate of each line card to fully seat the line card.
- Step 6** Press down on the ejector tab to secure the line card and connect it to the backplane.
- Step 7** Use a flat-head screwdriver to turn the locking tab so that it overlaps the 4xDMT-2 to prevent inadvertent dislodging. Figure 6 shows how to position the locking tab.

**Figure 6** Positioning the Locking Tab for the 4xDMT-2 Installation

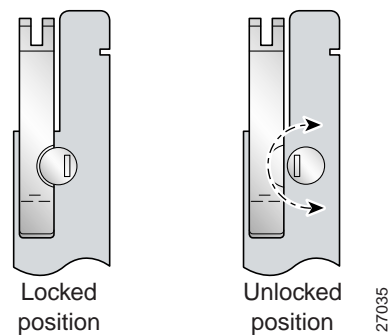

**Note** It is not necessary to lock the 4xDMT-2s in the Cisco 6130 with NI-2 chassis.

- Step 8** Verify that the STATUS LED is solid green after the brief self-test. If the STATUS LED is not green after the self-test, refer to the appropriate hardware installation guide for your chassis for troubleshooting procedures.

**Note**

If you are installing the line card for the first time, refer to the provisioning procedures in the appropriate software guide for your chassis.

## Traffic Handling

The maximum downstream rate for the 4xDMT-2 is 8.032 Mbps. The maximum upstream rate is 864 kbps.

*Downstream* refers to data that is coming from the network interface card to the subscriber lines. *Upstream* refers to data that is coming from the subscriber lines to the network interface card.

## Standards and Certifications

Table 3 lists 4xDMT-2 standards and certifications.

**Table 3**     *Standards and Certifications*

Category	Description
International Telecommunication Union	G.992.1, Annex A; G.992.2, Annex A (G.lite)
ANSI	T1.413 Issue 2
NEBS Level 3	Bellcore GR-63-CORE, GR-1089-CORE
EMC	FCC Part 15, Class A; AS/NZS 3548; EN 55024; EN 55022; EN 50082-1
Safety	UL 1950, 3rd Edition IEC 950; EN 60950

## Related Documentation

A complete list of all DSL product related documentation is available on the World Wide Web at [http://www.cisco.com/univercd/cc/td/doc/product/dsl\\_prod/index.htm](http://www.cisco.com/univercd/cc/td/doc/product/dsl_prod/index.htm)

## Obtaining Documentation

The following sections provide sources for obtaining documentation from Cisco Systems.

### World Wide Web

You can access the most current Cisco documentation on the World Wide Web at <http://www.cisco.com>, <http://www-china.cisco.com>, or <http://www-europe.cisco.com>.

## Documentation CD-ROM

Cisco documentation and additional literature are available in a CD-ROM package, which ships with your product. The Documentation CD-ROM is updated monthly. Therefore, it is probably more current than printed documentation. The CD-ROM package is available as a single unit or as an annual subscription.

## Ordering Documentation

Registered CCO users can order the Documentation CD-ROM and other Cisco Product documentation through our online Subscription Services at <http://www.cisco.com/cgi-bin/subcat/kaojump.cgi>.

Nonregistered CCO users can order documentation through a local account representative by calling Cisco's corporate headquarters (California, USA) at 408 526-4000 or, in North America, call 800 553-NETS (6387).

## Obtaining Technical Assistance

Cisco provides Cisco Connection Online (CCO) as a starting point for all technical assistance. Warranty or maintenance contract customers can use the Technical Assistance Center. All customers can submit technical feedback on Cisco documentation using the web, e-mail, a self-addressed stamped response card included in many printed docs, or by sending mail to Cisco.

## Cisco Connection Online

Cisco continues to revolutionize how business is done on the Internet. Cisco Connection Online is the foundation of a suite of interactive, networked services that provides immediate, open access to Cisco information and resources at anytime, from anywhere in the world. This highly integrated Internet application is a powerful, easy-to-use tool for doing business with Cisco.

CCO's broad range of features and services helps customers and partners to streamline business processes and improve productivity. Through CCO, you will find information about Cisco and our networking solutions, services, and programs. In addition, you can resolve technical issues with online support services, download and test software packages, and order Cisco learning materials and merchandise. Valuable online skill assessment, training, and certification programs are also available.

Customers and partners can self-register on CCO to obtain additional personalized information and services. Registered users may order products, check on the status of an order and view benefits specific to their relationships with Cisco.

You can access CCO in the following ways:

- WWW: [www.cisco.com](http://www.cisco.com)
- Telnet: [cco.cisco.com](telnet://cco.cisco.com)
- Modem using standard connection rates and the following terminal settings: VT100 emulation; 8 data bits; no parity; and 1 stop bit.
  - From North America, call 408 526-8070
  - From Europe, call 33 1 64 46 40 82

You can e-mail questions about using CCO to [cco-team@cisco.com](mailto:cco-team@cisco.com).

## Technical Assistance Center

The Cisco Technical Assistance Center (TAC) is available to warranty or maintenance contract customers who need technical assistance with a Cisco product that is under warranty or covered by a maintenance contract.

To display the TAC web site that includes links to technical support information and software upgrades and for requesting TAC support, use [www.cisco.com/techsupport](http://www.cisco.com/techsupport).

To contact by e-mail, use one of the following:

Language	E-mail Address
English	<a href="mailto:tac@cisco.com">tac@cisco.com</a>
Hanzi (Chinese)	<a href="mailto:chinese-tac@cisco.com">chinese-tac@cisco.com</a>
Kanji (Japanese)	<a href="mailto:japan-tac@cisco.com">japan-tac@cisco.com</a>
Hangul (Korean)	<a href="mailto:korea-tac@cisco.com">korea-tac@cisco.com</a>
Spanish	<a href="mailto:tac@cisco.com">tac@cisco.com</a>
Thai	<a href="mailto:thai-tac@cisco.com">thai-tac@cisco.com</a>

In North America, TAC can be reached at 800 553-2447 or 408 526-7209. For other telephone numbers and TAC e-mail addresses worldwide, consult the following web site:  
<http://www.cisco.com/warp/public/687/Directory/DirTAC.shtml>.

## Documentation Feedback

If you are reading Cisco product documentation on the World Wide Web, you can submit technical comments electronically. Click **Feedback** in the toolbar and select **Documentation**. After you complete the form, click **Submit** to send it to Cisco.

You can e-mail your comments to [bug-doc@cisco.com](mailto:bug-doc@cisco.com).

To submit your comments by mail, for your convenience many documents contain a response card behind the front cover. Otherwise, you can mail your comments to the following address:

Cisco Systems, Inc.  
 Document Resource Connection  
 170 West Tasman Drive  
 San Jose, CA 95134-9883

We appreciate and value your comments.

This document is to be used in conjunction with the *Related Documentation* publication.

Access Registrar, AccessPath, Any to Any, Are You Ready, AtmDirector, Browse with Me, CCDA, CCDE, CCDP, CCIE, CCNA, CCNP, CCSI, CD-PAC, the Cisco logo, Cisco Certified Internetwork Expert logo, *CiscoLink*, the Cisco Management Connection logo, the Cisco NetWorks logo, the Cisco Powered Network logo, Cisco Systems Capital, the Cisco Systems Capital logo, Cisco Systems Networking Academy, the Cisco Systems Networking Academy logo, the Cisco Technologies logo, Fast Step, FireRunner, Follow Me Browsing, FormShare, GigaStack, IGX, Intelligence in the Optical Core, Internet Quotient, IP/VC, IQ Breakthrough, IQ Expertise, IQ FastTrack, IQ Readiness Scorecard, The IQ Logo, Kernel Proxy, MGX, Natural Network Viewer, NetSonar, Network Registrar, the Networkers logo, *Packet*, PIX, Point and Click Internetworking, Policy Builder, Precept, RateMUX, ReyMaster, ReyView, ScriptShare, Secure Script, Shop with Me, SlideCast, SMARTnet, SVX, *The Cell*, TrafficDirector, TransPath, VlanDirector, Voice LAN, Wavelength Router, Workgroup Director, and Workgroup Stack are trademarks; Changing the Way We Work, Live, Play, and Learn, Empowering the Internet Generation, The Internet Economy, and The New Internet Economy are service marks; and Aironet, ASIST, BPX, Catalyst, Cisco, Cisco IOS, the Cisco IOS logo, Cisco Systems, the Cisco Systems logo, the Cisco Systems Cisco Press logo, CollisionFree, Enterprise/Solver, EtherChannel, EtherSwitch, FastHub, FastLink, FastPAD, FastSwitch, GeoTel, IOS, IP/TV, IPX, LightStream,

LightSwitch, MICA, NetRanger, Post-Routing, Pre-Routing, Registrar, StrataView Plus, Stratm, TeleRouter, and VCO are registered trademarks of Cisco Systems, Inc. or its affiliates in the U.S. and certain other countries. All other trademarks mentioned in this document are the property of their respective owners. The use of the word partner does not imply a partnership relationship between Cisco and any other company. (0005R)

Copyright © 2000, Cisco Systems, Inc.  
All rights reserved.

