



# Cisco 6130 NI-1 to NI-2 Upgrade Kit Conversion Procedures

---

**June 29, 2000**

This document provides the procedures to convert from a Cisco 6130 with network interface-1 (NI-1) card system to a Cisco 6130 with network interface-2 (NI-2) card system.



**Note**

---

Currently the Cisco 6130 with NI-2 system only supports quad-port DMT-2 ATU-C (4xDMT-2), quad-port flexi ATU-C (4xflexi), and quad-port STU-C (4xSDSL) line cards.

---

## Contents

These release notes describe the following topics:

- Conversion Prerequisites, page 2
- Required Tools and Equipment, page 2
- Safety Requirements, page 3
- Subtended Network Configuration Overview, page 9
- Cisco 6130 NI-1 to NI-2 Conversion Procedures, page 12
- Related Documentation, page 55
- Obtaining Documentation, page 56
- Obtaining Technical Assistance, page 56



# Conversion Prerequisites

The following upgrade kits need to be installed on your system prior to beginning these conversion procedures:

- Cisco 6130 Thermal Upgrade Kit (Part number 6130-THERMAL-UPGD)—Necessary to ensure that your Cisco 6130 chassis can accommodate higher-density line cards (for example, 4xflexi line cards). The following components of the thermal upgrade kit need to be installed:
  - Cisco 6130 chassis ventilation cover
  - New power rating label
- Direct Connect NEBS Compliance Kit (Part number 6100-NU-01)—Necessary to ensure that your Cisco 6130 chassis is compliant for a Direct Connect configuration.
  - Ferrites on the power connections cables
  - Thermal shield

# Required Tools and Equipment

Table 1 lists the tools and equipment that are required to convert from a Cisco 6130 with NI-1 card system to a Cisco 6130 with NI-2 card system.

**Table 1** *Tool and Equipment Requirements Checklist*

Check	Tools and Equipment
	<b>Hardware Components</b>
	Cisco 6100 NI-1 to NI-2 Upgrade Kit <ul style="list-style-type: none"> <li>• System I/O card for NI-2 system                             <ul style="list-style-type: none"> <li>– Plastic ESD shield</li> <li>– Component safety shield</li> <li>– EMI cover and cover bracket</li> </ul> </li> <li>• Fan tray alarm cable (part number 72-1912-01)</li> <li>• Cisco 6130 chassis front cover</li> <li>• Lexan shield for Cisco 6100 chassis backplane</li> <li>• <i>Cisco NI-1 to NI-2 Line Card Upgrade Utility CD</i></li> </ul>
	NI-2 card (DS3 or OC-3)
	Two blank faceplates
	<b>Tools</b>
	A 3/16-inch flat-head screwdriver
	A Phillips-head screwdriver
	A one-quarter inch socket driver or wrench
	Necessary equipment for ESD protection—Required whenever you handle Cisco DSLAM equipment, which includes the chassis and cards
	Standoff screws

**Table 1** *Tool and Equipment Requirements Checklist (continued)*

Check	Tools and Equipment
	Backplane screws—Included on the backplane
	Wire-wrapping tool
	Wire stripper
	Wire for connections <ul style="list-style-type: none"> <li>• 12 AWG black and red copper solid or stranded—Used for Cisco 6130 chassis power connections</li> <li>• 12 AWG or thicker green or green with yellow stripes copper stranded—Used for the Cisco 6130 chassis grounding</li> </ul>
	Ferrites that yield an impedance of 200 ohms +/-20 percent at 100 MHz
	Tie wraps
	Coaxial cable <ul style="list-style-type: none"> <li>• Type 734A or equivalent</li> <li>• Type 735A or equivalent</li> </ul>
	Fiber cable—Used to connect the OC-3 NI-2 card

## Safety Requirements

This section describes safety requirements for the Cisco 6100 Series system. Before you work on the Cisco 6100 Series system, ensure that you have met all the criteria in this section. This section describes the following areas:

- Safety Guidelines, page 3
- Preventing Electrostatic Discharge Damage, page 8
- General Maintenance Guidelines, page 9

## Safety Guidelines

Before working on the equipment, be aware of standard safety guidelines and the hazards that are involved in working with electrical circuitry to prevent accidents. Adhere to the following cautions and warnings for safe and hazard-free installation.



### Note

To see translations of the warnings that appear in this publication, refer to the *Regulatory Compliance and Safety Information for the Cisco 6100 Series System* document that accompanied this product.



### Tips

In the following warnings, the terms *cover panel* and *safety cover* refer to the Cisco 6100/6130 chassis front cover.



Caution

Before you start the installation procedures, read the entire document for important information and safety warnings.



Caution

Proper ESD protection is required whenever you handle Cisco digital subscriber line access multiplexer (DSLAM) equipment. Installation and maintenance personnel should be properly grounded using ground straps to eliminate the risk of ESD damage to the equipment. Cards are subject to ESD damage whenever they are removed from the chassis.



Caution

Mixing incompatible line cards can cause unpredictable system behavior. Refer to the *Cisco 6130 with NI-2 Hardware Installation Guide* for intermixing compatibility.



Caution

Be careful when you remove the standoff screws and reinsert the screws into the screw holes on the backplane so that the backplane circuitry does not become damaged.



Caution

Installing the line cards in the chassis with the power leads reversed can damage the line cards.



Caution

If fuses are already installed in the fuse and alarm panel, remove them. You can replace the fuses after the system is installed. Do not power up the system while you install and connect the system.



Caution

If the power connections are improperly connected and power is applied while the line cards are installed, the line cards and chassis could be damaged.



Caution

It is important that the chassis cooling fans run continuously.



Caution

Any line card that is only partially connected to the backplane can disrupt system operation.











Warning

The customer 48 volt power system must provide reinforced insulation between the primary AC power and the 48 VDC output.



Warning

There is the danger of explosion if the battery is replaced incorrectly. Replace the battery only with the same or equivalent type recommended by the manufacturer. Dispose of used batteries according to the manufacturer's instructions.

-  **Warning** Two people are required to lift the chassis. Grasp the chassis underneath the lower edge and lift with both hands. To prevent injury, keep your back straight and lift with your legs, not your back.
- 
-  **Warning** To prevent bodily injury when mounting or servicing this unit in a rack, you must take special precautions to ensure that the system remains stable. The following guidelines are provided to ensure your safety:
- This unit should be mounted at the bottom of the rack if it is the only unit in the rack.
  - When mounting this unit in a partially filled rack, load the rack from the bottom to the top with the heaviest component at the bottom of the rack.
  - If the rack is provided with stabilizing devices, install the stabilizers before mounting or servicing the unit in the rack.
- 
-  **Warning** Class 1 laser product.
- 
-  **Warning** Because invisible laser radiation may be emitted from the aperture of the OC-3 NI-2 card optical interface port when no optical cable is connected, avoid exposure to laser radiation and do not stare into an open aperture.
- 
-  **Warning** Use copper conductors only.
- 
-  **Warning** A readily accessible two-poled disconnect device must be incorporated in the fixed wiring.
- 
-  **Warning** The DS3 ports are not intended to be connected to cables that run outside the building where it is installed. For any connections outside the building, the DS3 ports must be connected to a network termination unit (NTU). NTU devices should comply with appropriate national safety standards such as UL 1950, CSA 950, EN 60950, IEC 950, and AS 3260.
- 
-  **Warning** Never install telephone wiring during an electrical storm.
- 
-  **Warning** Do not reach into a vacant slot or chassis while you install or remove a line card or a fan. Exposed circuitry could constitute an energy hazard.
-



Warning

Ethernet cables must be shielded when used in a central office environment.



Warning

An exposed wire lead from a DC-input power source can conduct harmful levels of electricity. Be sure that no exposed portion of the DC-input power source wire extends from the terminal block plug.



Warning

Blank faceplates and cover panels serve three important functions: they prevent exposure to hazardous voltages and currents inside the chassis; they contain electromagnetic interference (EMI) that might disrupt other equipment; and they direct the flow of cooling air through the chassis. Do not operate the system unless all cards, faceplates, and front covers are in place.



Warning

When installing the unit, the ground connection must always be made first and disconnected last.



Warning

This equipment is intended to be grounded. Ensure that the host is connected to earth ground during normal use.



Warning

This equipment needs to be grounded. Use a green and yellow 12 to 14 American Wire Gauge (AWG) ground wire to connect the host to earth ground during normal use.



Warning

Incorrect connection of this or connected equipment to a general purpose outlet could result in a hazardous situation.



Warning

Read the installation instructions before you connect the system to its power source.



Warning

Only trained and qualified personnel should be allowed to install, replace, or service this equipment.













Warning

The ISDN connection is regarded as a source of voltage that should be inaccessible to user contact. Do not attempt to tamper with or open any public telephone operator (PTO)-provided equipment or connection hardware. Any hardwired connection (other than by a nonremovable, connect-one-time-only plug) must be made only by PTO staff or suitably trained engineers.



Warning

Do not stare into the beam or view it directly with optical instruments.

-  **Warning** Do not work on the system or connect or disconnect cables during periods of lightning activity.
-  **Warning** Use caution when installing or modifying telephone lines.
-  **Warning** This unit has more than one power supply connection; all connections must be removed completely to completely remove power from the unit.
-  **Warning** To reduce the risk of fire, use only No. 26 AWG or larger telecommunication line cord.
-  **Warning** To prevent the system from overheating, do not operate it in an area that exceeds the maximum recommended ambient temperature of 104°F (40°C).
-  **Warning** Metal objects heat up when connected to power and ground, and can cause serious burns.
-  **Warning** Secure all power cabling when installing this unit to avoid disturbing field-wiring connections.
-  **Warning** The power supply circuitry for the equipment can constitute an energy hazard. Before you install or replace the equipment, remove all jewelry (including rings, necklaces, and watches). Metal objects can come into contact with exposed power supply wiring or circuitry inside the DSLAM equipment. This could cause the metal objects to heat up and cause serious burns or weld the metal object to the equipment.
-  **Warning** Ultimate disposal of this product should be handled according to all national laws and regulations.
-  **Warning** This unit is intended for installation in restricted access areas. A restricted access area is where access can only be gained by service personnel through the use of a special tool, lock and key, or other means of security, and is controlled by the authority responsible for the location.
-  **Warning** Connect the unit only to DC power source that complies with the Safety Extra-Low Voltage (SELV) requirements in IEC 60950 based safety standards.



Warning

This product requires short-circuit (overcurrent) protection, to be provided as part of the building installation. Install only in accordance with national and local wiring regulations.



Warning

Care must be given to connecting units to the supply circuit so that wiring is not overloaded.



Warning

Never install telephone jacks in wet locations unless the jack is specifically designed for wet locations.



Warning

Do not use a telephone to report a gas leak in the vicinity of the leak.



Warning

Avoid using a telephone (other than a cordless type) during an electrical storm. There may be a remote risk of electric shock from lightning.



Warning

Never touch uninsulated telephone wires or terminals unless the telephone line has been disconnected at the network interface.



Warning

This is a Class A product based on the standard of the Voluntary Control Council for Interference by Information Technology Equipment (VCCI). If this equipment is used in a domestic environment, radio disturbance may arise. When such trouble occurs, the user may be required to take corrective actions.



Warning

Do not use this product near water; for example, near a bath tub, wash bowl, kitchen sink or laundry tub, in a wet basement, or near a swimming pool.



Warning

During this procedure, wear grounding wrist straps to avoid ESD damage to the card. Do not directly touch the backplane with your hand or any metal tool, or you could shock yourself.

## Preventing Electrostatic Discharge Damage

Proper ESD protection is required whenever you handle Cisco DSLAM equipment. Installation and maintenance personnel should be properly grounded using ground straps to eliminate the risk of ESD damage to the equipment. Cards are subject to ESD damage whenever they are removed from the chassis.



## General Maintenance Guidelines

This section covers the following topics:

- Hot-Swapping Line Cards, page 9
- Installation and Replacement Suggestions, page 9

## Hot-Swapping Line Cards

The line cards support hot swapping. Hot swapping allows you to remove and replace the line cards without disconnecting the system power. When the system detects that you have added or removed a line card, it automatically runs diagnostic and discovery routines, and acknowledges the presence or absence of the card.

## Installation and Replacement Suggestions

The following examples list recommended card installation and replacement practices for the Cisco 6130 system cards.



**Caution**

---

Any line card that is only partially connected to the backplane can disrupt system operation.

---

- Do not force the card into or onto the chassis backplane connectors. This action can damage the pins on the connectors if they are not aligned properly with the card.
- Do not force the line card into its slot. This action can damage the pins on the backplane if they are not aligned properly with the line card.
- Ensure that the system I/O card is straight and parallel to the chassis backplane when you install the card onto the connectors. The pins on the connectors can be damaged if the card is not installed correctly.
- Ensure that the card is straight and not at an angle when you install the card in the slot. Installing the card at an angle can damage the card. Use the guide rails to install the card correctly.
- Fully depress the ejector tabs to ensure that the card connector mates with the backplane correctly. Firmly seat the card in the slot.

## Subtended Network Configuration Overview

A subtended network configuration

- Services and aggregates the data from one or more remotely located Cisco 6130 chassis into a subtending host chassis to take advantage of the data network interface on the subtending host chassis
- Provides additional benefits by reducing the number of ATM edge-switch ports that are required to terminate the chassis

The term *subtending* refers to the host chassis, and *subtended* refers to the downstream chassis in a subtended network.

A subtended network configuration supports the following features:

- The capacity to run data as fast as the speed of its subtended link. Uplink speed cannot exceed the OC-3 speed.
- Four arbitration priorities, one for each quality of service (QoS) level. The supported QoS service levels are
  - Constant bit rate (CBR) for rate-limited services that require guaranteed bandwidth and bounded delay
  - Variable bit rate-real time (VBR-rt) for delay-sensitive voice and video services
  - Variable bit rate-non-real time (VBR-nrt) for high-priority data services
  - Unspecified bit rate (UBR) for low-priority data services
- Explicit forward congestion indication (EFCI) marking for available bit rate (ABR) service support.
- Guaranteed frame rate (GFR).
- Tree or daisy chain configurations for DS3 subtended Cisco 6130 chassis.
- Daisy chain configurations for OC-3 subtended Cisco 6130 chassis.
- Fair access to the trunk port for each subtended chassis.
- A network trunk port that operates as fast as any subtended link.

The NI-2 card provides three types of subtended network connections:

- A high-speed OC-3 optical ATM interface that supports single-mode fiber (SMF) intermediate range
- A high-speed OC-3 optical ATM interface that supports multimode fiber (MMF) short range
- A DS3 ATM interface

The following sections detail the three types of subtending network connections.

## Subtended Network Configuration with DS3 NI-2 Cards

In a subtended network configuration using DS3 NI-2 cards, you can subtend a Cisco 6130 chassis to four tiers, with up to twelve chassis, all connecting through one subtending host chassis to the ATM backbone).

Figure 1 shows typical DS3-configured Cisco 6130 systems subtended in a combined subtending tree topology with daisy chain. The subtending host chassis at the top of the subtending tree connects directly to the ATM switch. The middle two Cisco 6130 chassis in the lowest level are daisy chained. TRNK 1 refers to the single network trunk or Cisco 6130 chassis subtended network interface. SBTD 2 and SBTD 3 refer to the two Cisco 6130 chassis subtended interfaces. You make network interface connections at the system I/O card that is installed on the Cisco 6130 chassis backplane.

Figure 1 Subtended Network Configuration Using DS3 NI-2 Cards

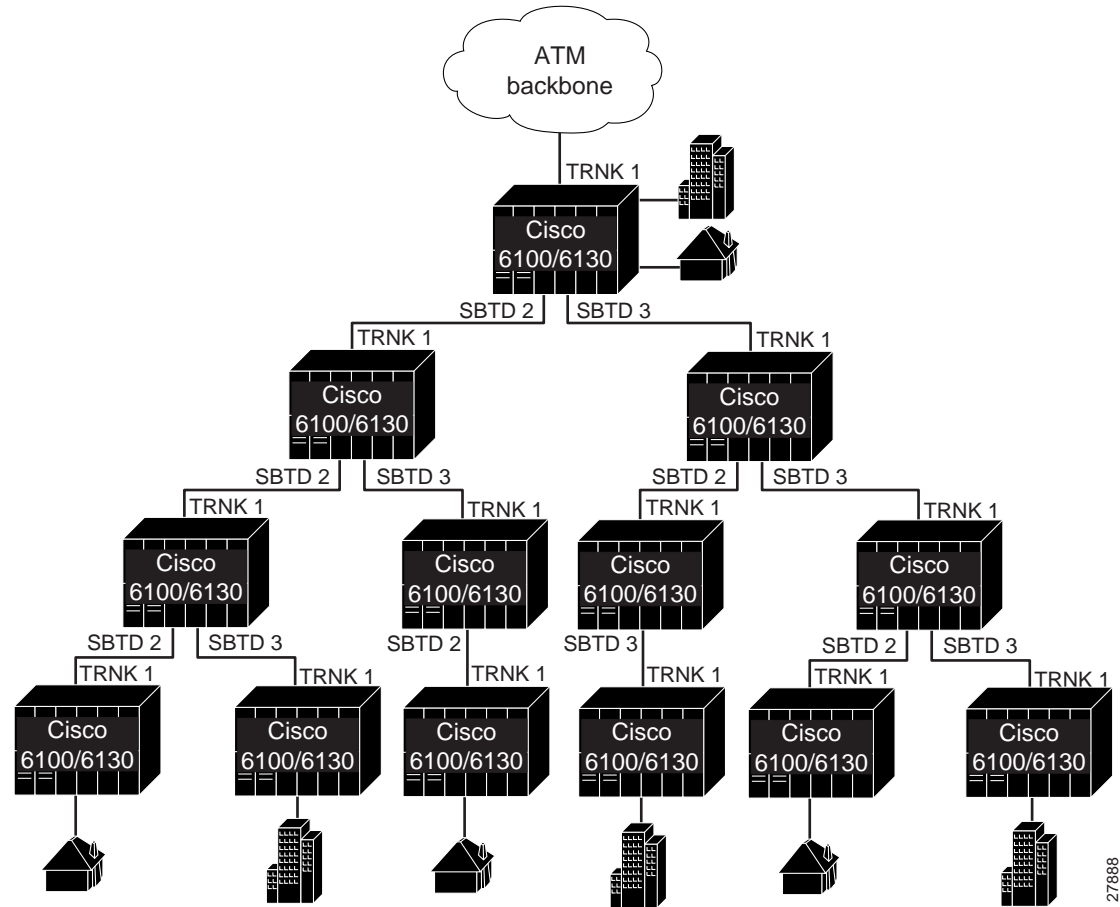

**Note**

If you are combining Cisco 6130 with NI-1 systems and Cisco 6130 with NI-2 systems in a subtending tree topology, the subtending host chassis connecting to the ATM switch must be a Cisco 6130 with NI-2 system. For better performance, Cisco does not recommend mixing NI-1 and NI-2 systems in the same subtending tree topology.

You can subtend Cisco 6130 chassis with DS3 NI-2 cards in a continuous daisy chain. However, this subtending scheme is not optimal for data throughput for daisy-chained Cisco 6130 chassis that use DS3 NI-2 cards.

Cisco IOS software is not implemented to manage the primary Cisco 6130 chassis and all subtended Cisco 6130 chassis as a single large Cisco 6130 with NI-2 card system. The initial release of Cisco 6130 with NI-2 system emphasizes bandwidth aggregation. Each Cisco 6130 supports an independent IOS processor and MIB.

27888

## Subtended Network Configuration with OC-3 NI-2 Cards

In a subtended network configuration using OC-3 NI-2 cards (SMF or MMF), you can subtend up to twelve OC-3 configured chassis in a daisy chain, all connecting through one subtending host chassis to the ATM backbone (see Figure 2).

**Figure 2** Subtended Network Configuration Using OC-3 NI-2 Cards

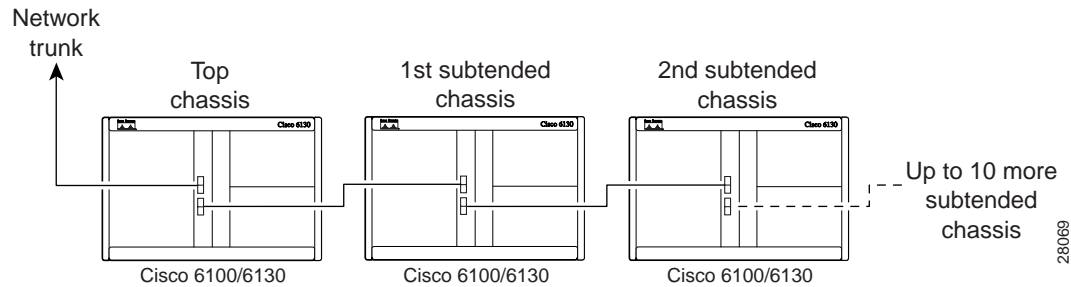

**Note**

Cisco 6130 with NI-1 systems do not support a daisy chain subtended network configuration.

## Cisco 6130 NI-1 to NI-2 Conversion Procedures

The following sections detail the procedures for converting your system from a Cisco 6130 with NI-1 system to a Cisco 6130 with NI-2 system.



**Warning**

Only trained and qualified personnel should be allowed to install, replace, or service this equipment.



**Note**

Before installing and cabling the equipment, be aware of standard safety practices and the hazards involved in working with electrical circuitry to prevent accidents. See the “Safety Requirements” section on page 3 for all cautions and warnings that are necessary to ensure a safe and hazard-free installation.

To see translations of the warnings that appear in this publication, refer to the *Regulatory Compliance and Safety Information for the Cisco 6100 Series System* document.

## Conversion Checklist

When you convert your system to a Cisco 6130 with NI-2 system, be sure that you follow the conversion procedures in the proper sequence. Table 2 is a checklist of the conversion steps in the order in which they should occur. Detailed conversion instructions are located in the sections following Table 2.



### Caution

Proper ESD protection is required whenever you handle Cisco DSLAM equipment. Installation and maintenance personnel should be properly grounded using ground straps to eliminate the risk of ESD damage to the equipment. Cards are subject to ESD damage whenever they are removed from the chassis.

**Table 2**    *Conversion Procedure Checklist*

Check	Conversion Step
	1. Upgrade the ViewRunner management software.
	2. Upgrade the Cisco 6130 system node software to Release 3.0.0.
	3. Run the NI-1 to NI-2 conversion utility.
	4. Run the NI-2 preparation build.
	5. Remove the power from the system.
	6. Remove the current system I/O card.
	7. Remove the current DS3 subtending I/O card (if applicable).
	8. Remove the alarm contact wires.
	9. Disconnect the Cisco 6130 power connections.
	10. Disconnect the Cisco 6130 cables.
	11. Remove the Cisco 6130 chassis ground (if applicable).
	12. Install the new lexan shield.
	13. Ground the Cisco 6130 chassis (if applicable).
	14. Connect the Cisco 6130 to the Cisco 6120.
	15. Attach the Cisco 6130 power connections to the fuse and alarm panel.
	16. Install the new system I/O card.
	17. Connect the fan tray.
	18. Connect the alarm contacts.
	19. Remove the DS3 STM <sup>1</sup> (if applicable).
	20. Remove the system controller card.
	21. Remove the NI-1 card.
	22. Verify correct fuses.
	23. Apply power to the system.
	24. Verify that the fan tray is operational.
	25. Install the NI-2 card.
	26. Install a blank faceplate in the DS3 STM and the system controller card slots.
	27. Install the xTU-C <sup>2</sup> line cards in the Cisco 6130 chassis.

**Table 2** Conversion Procedure Checklist (continued)

Check	Conversion Step
	28. Connect the NI-2 card to the network.
	29. Reconnect the subtended network configuration (optional).
	30. Connect the software management system to the Cisco 6130.
	31. Connect a console terminal.
	32. Connect the auxiliary port (optional).
	33. Complete software configuration and support commands.
	34. Load the subscriber information into the NI-2 card.
	35. Install the new front cover.
	36. Close the rear cover.
	37. Run the ViewRunner to CDM <sup>3</sup> migration utility.

1. STM = subtend host module
2. *xTU-C* is a generic term referring to a Transmission Unit - central office, which can be a 4xDMT-2, 4xflexi, or 4xSDSL line card.
3. CDM = Cisco DSL Manager

## Conversion Procedures

The following sections detail the procedures for converting your system from a Cisco 6130 with NI-1 to a Cisco 6130 with NI-2.

### Upgrade the ViewRunner Management Software

You need to upgrade the ViewRunner management software to Release 3.0.0. For software upgrade procedures, refer to either the *ViewRunner for Windows Installation and Administration Guide* or the *ViewRunner for HP OpenView Installation and Administration Guide*.

Refer to the *Release Notes for ViewRunner for Windows Release 3.0.0* or *Release Notes for ViewRunner for HP OpenView* for necessary software patches.

### Upgrade the Cisco 6130 System Node Software

Complete the following steps to upgrade the Cisco 6130 system node software:



#### Note

If your system is already running Release 3.0.0 or Release 3.1.0 code, proceed to the “Run the NI-1 to NI-2 Conversion Utility” section on page 15.



#### Caution

The procedure that is outlined in the following steps will force the Cisco 6130 system to stop providing DSL service for the duration of the conversion procedures. Do not proceed unless this is acceptable.

**Caution**

Proper ESD protection is required whenever you handle Cisco DSLAM equipment. Installation and maintenance personnel should be properly grounded using ground straps to eliminate the risk of ESD damage to the equipment. Cards are subject to ESD damage whenever they are removed from the chassis.

- Step 1** Remove all cards from the Cisco 6130 except for the system controller card, 4xflexi line cards, and 4xSDSL line cards.
- Lift up the ejector tab(s). This action disconnects the card from the backplane.
  - Carefully slide the card out of the slot.
  - Repeat for each additional card.

**Note**

To prevent damage to the cards that are removed from the chassis, place the cards upright in a tray.

- Step 2** Download Release 3.0.0 using one of following methods:
- Go to <http://www.cisco.com/cgi-bin/tablebuild.pl/looprunner> and download Release 3.0.0 to your computer.
  - Go to [www.cisco.com](http://www.cisco.com) and log in.
- Select **Software Center > Access Software > 6100 Series**. Download either the c6100-3.0.exe file or the c6100-3.0.tar file.
- Step 3** Upgrade the Cisco 6130 system node software to Release 3.0.0.

**Note**

During the software upgrade, the STATUS LEDs on the xTU-C and system controller cards will flash.

For detailed node upgrade procedures, refer to either the *ViewRunner* or *Windows User Guide* or the *ViewRunner for HP OpenView User Guide*.

**Note**

During the upgrade process you may receive a warning that certain hardware revisions were found in the Cisco 6130 but not listed in the .rdf file. This warning is followed by a list of the hardware revisions. This list refers to the cards that were removed from the chassis in Step 1. This is an expected response. Click **Next** or **Ok** to continue.

- Step 4** Verify that the STATUS LEDs on all line cards are solid green when the software download is complete. The software download takes several minutes.

## Run the NI-1 to NI-2 Conversion Utility

For a complete conversion of the Cisco 6130 system configuration including subscribers and PVCs from an NI-1 architecture to an NI-2 architecture, you can run the NI-1 to NI-2 migration utility.

You must be running ViewRunner Release 3.0.0 before you can run the NI-1 to NI-2 migration utility. The NI-1 to NI-2 migration is applicable to both ViewRunner for Windows Release 3.0.0 and ViewRunner for HP OpenView Release 3.0.0.

The utility matches current subscriber profiles to the predefined utility profiles. The utility builds new subscriber profiles based on your current profile data. The utility converts the NSS file to a Cisco Internet Operating System (IOS) configuration file. You can run the utility on both a Microsoft Windows platform and a Sun Solaris platform; the utility runs the same way on either platform.

Before you install and run the NI-1 to NI-2 migration utility package, verify that the following requirements are true:

- The NI-1 is in Direct Connect configuration mode.
- You have saved the NSS file in ViewRunner for Windows or ViewRunner for HP-OpenView 3.0.
- The node software is version 2.2.1 to 3.0.

### Downloading the Utility Packages from the Cisco Web Site

To access the utility packages on the Cisco web site (CCO), complete the following steps:

- 
- Step 1** Access CCO in one of the following ways:
- WWW: [www.cisco.com](http://www.cisco.com)
  - Telnet: [cco.cisco.com](telnet://cco.cisco.com)
  - Modem using standard connection rates and the following terminal settings: VT100 emulation; 8 data bits; no parity; and 1 stop bit.
    - From North America, call 408 526-8070
    - From Europe, call 33 1 64 46 40 82
- Step 2** Click Software Center under Service and Support.
- Step 3** Click Login on the menu bar.
- Step 4** In the Login dialog box, type your user name and password, then click **OK**.
- Step 5** Click Network Mgmt Products on the Software Center web page to access the Network Management Products web page.
- Step 6** Click Cisco DSL Manager under Network Management Products to access the CDM utility files.
- Step 7** Under Select a File to Download, find the appropriate utility files that you need to install.

### Running the NI-1 to NI-2 Migration Utility

To run the NI-1 to NI-2 migration utility, complete the following steps:

- 
- Step 1** Download the migration utility package files from CCO (as described in the “Downloading the Utility Packages from the Cisco Web Site” section on page 16), or from the product CD-ROM.



- Step 2** Use the copy command for your platform (*cp* command in UNIX or the *copy* command on Windows) to copy the utility package directory from the source directory into your local directory.

```
cp /source_dir /dest_dir
```

An example of the directory structure is as follows:

```
Unix /cdrom0/CDM30/utilities/transition/unix
```

```
PC d:\utilities\transition\pc
```

- Step 3** After you have installed the directory that contains the package utility files, enter the following command to begin running the utility:

```
ni12ni2-n NSSFile -t TemplateFile [-c ConfigFile] [-r ReportFile] [-v ni2defaults.txt] [-f FCM]
```

The command options are as follow:

- -n NSS file - with path. This file must have the NSS extension. This file is required.
- -t template file. This file must have a TMP extension. This file is required.
- -v NI2defaults.txt - with path. This file is optional. If you do not enter a filename, the utility defaults to -v NI2defaults.
- -f FCM - with path (SCFeature Compatibility Matrix file). If you do not enter a filename, the utility defaults to -f FCM.

See the “NI-1 to NI-2 Migration Utility Input Examples” section on page 17 for some examples of using these command options.



**Note** If you do not specify a path, the utility assumes the path is the same as the NSS file path.

## NI-1 to NI-2 Migration Utility Input Examples

An example of running the utility on Windows follows:

```
ni1-to-ni2 -n C:\Program Files\Cisco\VR4W 3.0.0\System1.NSS \
-t C:\Program Files\Cisco\TemplateFile.TMP \
-c C:\Program Files\Cisco\System1.CFG \
-r C:\Program Files\Cisco\VR4W 3.0.0\System1.TMP \
-v C:\Program Files\Cisco\ni2defaults.txt \
-f C:\Program Files\Cisco\VR4W 3.0.0\SCFeatureCapabilityMatrix.csv
```

An example of running the utility on a Solaris platform follows:

```
ni1-to-ni2 -n /opt/CSCovrovs/NSS/172.21.177.22/172.21.177.22.19991011_192851.NSS \
-t /opt/CSCovrovs/TemplateFile.TMP \
-c /opt/CSCovrovs/NSS/172.21.177.22/172.21.177.22.19991011_192851.CFG \
-r /opt/CSCovrovs/NSS/172.21.177.22/172.21.177.22.19991011_192851.TMP \
-v /opt/CSCovrovs/conf/ni2defaults.txt \
-f /opt/CSCovrovs/CMF/SCFeatureCapabilityMatrix.csv
```

## NI-1 to NI-2 Migration Utility Output Files

The NI-1 to NI-2 migration utility creates the following output files:

- -c Config file - with path. If you do not specify a path, the utility assumes that the path is the same as the path for the NSS file, but with a .CFG extension.
- -r Report file - with path. If you do not specify a path, the utility assumes that the path is the same as the path for the NSS file, but with a .TMP extension.



**Note** If the utility cannot find one or more of the input files, or cannot create one or more of the output files, the utility exits with an error.

## Run the NI-2 Preparation Build

Complete the following steps to run the NI-2 preparation build:



**Caution**

The procedure that is outlined in the following steps will force the Cisco 6130 system to stop providing DSL service for the duration of the conversion procedures. Do not proceed unless this is acceptable.



**Caution**

Proper ESD protection is required whenever you handle Cisco DSLAM equipment. Installation and maintenance personnel should be properly grounded using ground straps to eliminate the risk of ESD damage to the equipment. Cards are subject to ESD damage whenever they are removed from the chassis.

**Step 1** Insert the *Cisco NI-1 to NI-2 Line Card Upgrade Utility CD*.

The CD contains the 3.0.0.A.rdf file along with images for the system controller card, 4xflexi line cards, and the 4xSDSL line cards.

**Step 2** Copy the .rdf and image files to the appropriate Windows or UNIX directories.

For Windows, copy the files into the folder where your program files are stored. For UNIX, copy the image files into the /tftpboot/ directory and the .rdf file into the /opt/CSCOVrovs/RDF/ directory.

**Step 3** Upgrade the Cisco 6130 system node software to Release c6100-3.0.0.A.



**Note** For detailed node upgrade procedures, refer to either the *ViewRunner for Windows User Guide* or the *ViewRunner for HP OpenView User Guide*.

During the upgrade process you may receive a warning that certain hardware revisions were found in the Cisco 6130 but not listed in the .rdf file. This warning is followed by a list of the hardware revisions. This list refers to the cards that were removed from the chassis in Step 1. This is an expected response. Click **Next** or **Ok** to continue.

The upgrade is successful and complete when the STATUS, ACTIVE, and four port LEDs are solid green on the 4xflexi and 4xSDSL line cards. The 4xflexi and 4xSDSL line cards will now boot in both an NI-1 or an NI-2 system.

**Caution**

---

During the software download, the boot ROM for the cards will be reprogrammed. Do not remove any cards from the chassis during the software download. If cards are removed from the chassis or loss of power occurs during this operation, the cards will lose the ability to boot up and will require an RMA repair.

---

**Caution**

---

Do not remove a 4xflexi or a 4xSDSL line card from the Cisco 6130 chassis unless the STATUS, ACTIVE, and four port LEDs are solid green. If line cards are removed from the chassis before the LEDs are solid green, the line cards will lose the ability to boot up and will require an RMA repair.

---

- Step 4** The chassis may now be used to upgrade additional 4xflexi or 4xSDSL line cards from other NI-1 systems that are currently being converted to NI-2 systems. To program the line card's boot ROM, insert the line cards into the chassis and the new image will download.
- Step 5** Remove the system controller card, 4xflexi line cards, and 4xSDSL line cards from the chassis.
- a. Lift up the ejector tab(s). This action disconnects the card from the backplane.
  - b. Carefully slide the card out of the slot.
  - c. Repeat for each xTU-C line card (if applicable) and the system controller card.

**Note**

---

To prevent damage to the cards that are removed from the chassis, place the cards upright in a tray.

---

## Remove the Power

The system should not be powered while you install and connect the Cisco 6130 system hardware components.

Remove power to the system with one of the following methods:

- Remove the fuses from the fuse and alarm panel
- Turn off the breakers in the fuse and alarm panel

## Remove the Current System I/O Card

Complete the following steps to remove a system I/O card from the Cisco 6130 chassis backplane:

**Note**

---

There are two versions of the system I/O card currently in the field. With the earlier version (prior to Release 2.4.0), the DS3 BNC connectors are located at the bottom left corner of the card and the 10BaseT Ethernet/LAN connector is located across the bottom of the card. The removal procedures are the same for each version of the system I/O card.

---

- 
- Step 1** Remove the optional rear cover, if your system has one.
- Step 2** Use a Phillips-head screwdriver to remove the two backplane screws that hold the plastic ESD shield over the system I/O card. Keep the backplane screws for future use.

Figure 3 shows the system I/O card removal.

**Figure 3** System I/O Card Removal

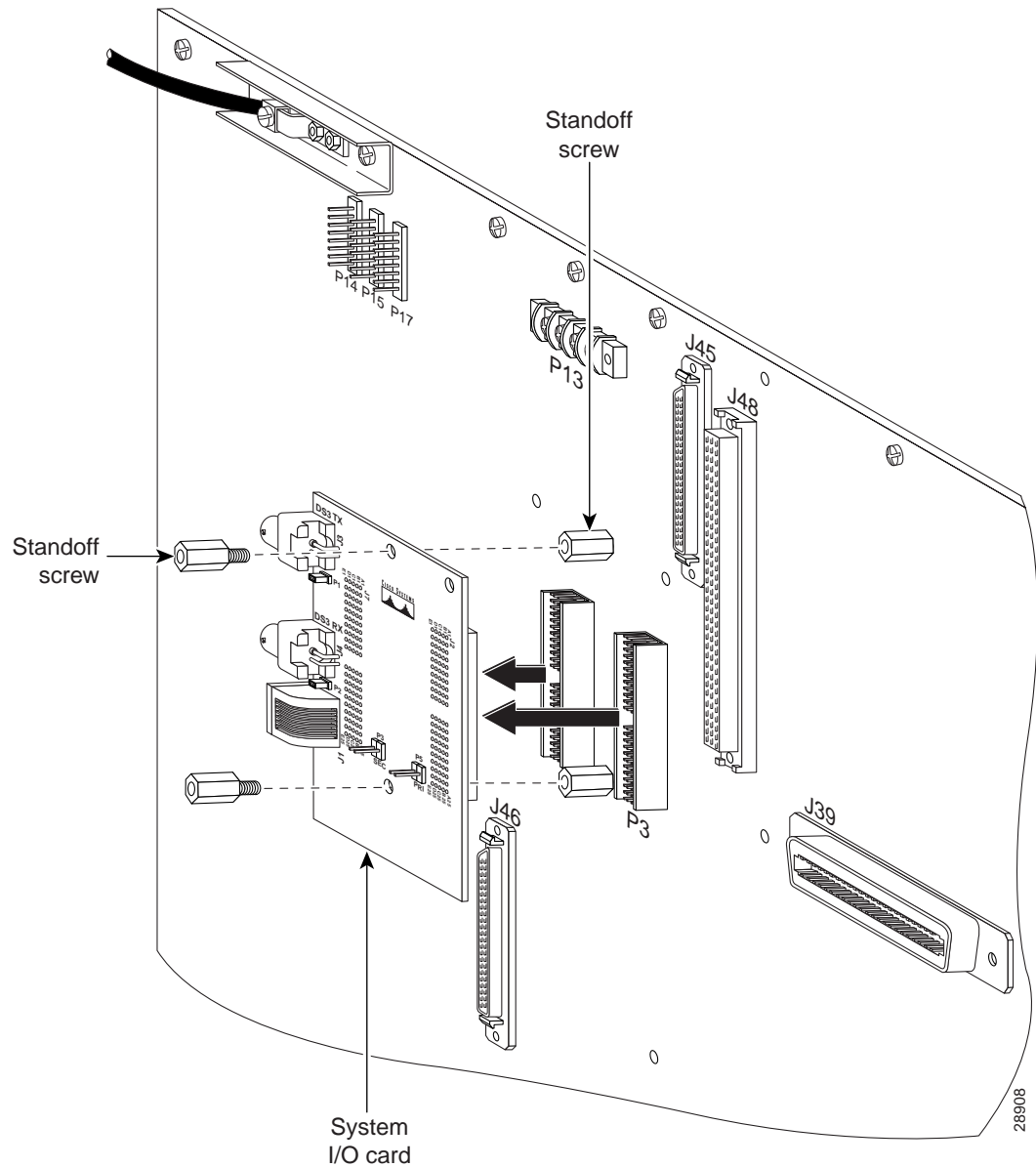

- Step 3** Disconnect the ViewRunner system from the Cisco 6130 chassis by removing the Ethernet cable from the 10BaseT Ethernet/LAN connector on the system I/O card.
- Step 4** Disconnect the DS3 NI-1 card from the network if you have a DS3 NI-1 card installed in slot 10 of the Cisco 6130 chassis.
- Disconnect the end of the cable that attaches to the receive (J4) DS3 BNC connector on the system I/O card on the chassis backplane.
  - Disconnect the end of the cable that attaches to the transmit (J3) DS3 BNC connector on the system I/O card on the chassis backplane.

- Step 5** Remove the coaxial cables from the DS3 BNC connectors (TX and RX) for the system I/O card on a subtended node chassis backplane.
- Step 6** Use a one-quarter inch socket driver or wrench to remove the two additional standoff screws that hold the system I/O card in place. Keep the standoff screws for future use.
- Step 7** Lift and disconnect the system I/O card from connectors P3 and P9, two 2-mm hard metric (HM) module connectors on the Cisco 6130 backplane.
- Step 8** Use a one-quarter inch socket driver or wrench to remove the two standoff screws from the system I/O card on the Cisco 6130 backplane. Keep the standoff screws for future use.
- 

## Remove the Current DS3 Subtending I/O Card



### Caution

Proper ESD protection is required whenever you handle Cisco DSLAM equipment. Installation and maintenance personnel should be properly grounded using ground straps to eliminate the risk of ESD damage to the equipment. Cards are subject to ESD damage whenever they are removed from the chassis.

---

Complete the following steps to remove a DS3 subtending I/O card from the Cisco 6130 chassis backplane:

---

- Step 1** Use a Phillips-head screwdriver to remove the two backplane screws that hold the plastic ESD shield over the DS3 subtending I/O card. Keep the backplane screws for future use.

Figure 4 shows the DS3 subtending I/O card removal.

**Figure 4** DS3 Subtending I/O Card Removal

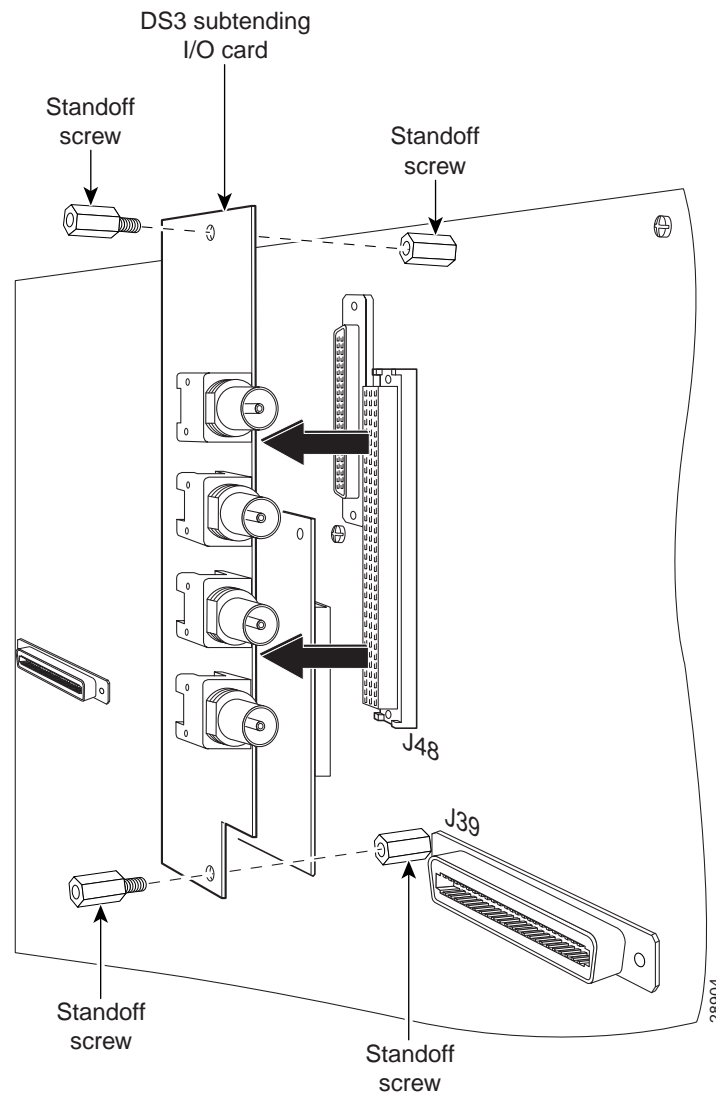

- Step 2** Remove the coaxial cables from the four DS3 BNC connectors (TX1, RX1, TX2, and RX2) on the DS3 subtending I/O card.
- Step 3** Use a one-quarter inch socket driver or wrench to remove the two additional standoff screws that hold the DS3 subtending I/O card in place. Keep the standoff screws for future use.
- Step 4** Lift and disconnect the DS3 subtending I/O card from connector J48, a 96-pin Deutsche Industrie Norm (DIN) connector on the subtending host chassis backplane.
- Step 5** Use a one-quarter inch socket driver or wrench to remove the two standoff screws from the DS3 subtending I/O card on the Cisco 6130 backplane. Keep the standoff screws for future use.

## Remove the Alarm Contact Wires

To disconnect the fan tray alarm contacts, complete the following steps:

- 
- Step 1** Remove the wire between P2 on the backplane of the fan tray and P14 (pin 7) on the backplane of the Cisco 6130 if you have a fan tray installed.
  - Step 2** Remove the wire between P2 on the backplane of the fan tray and P14 (pin 8) on the backplane of the Cisco 6130 if you have a fan tray installed.

Figure 5 shows how the fan tray two-position header (P2) connects to the fan tray alarm contacts (P14, pins 7 and 8) on the Cisco 6130 backplane.

**Figure 5** *Wiring the Fan Tray Alarm Contacts*

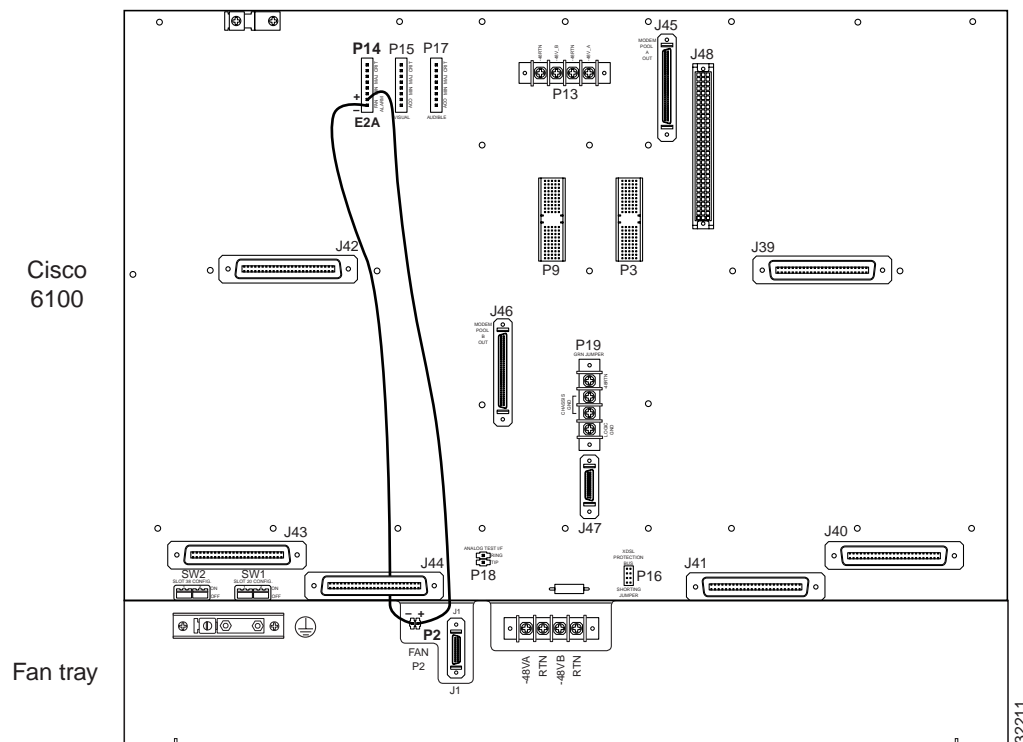

- 
- Step 3** Disconnect any additional alarm contacts as necessary.
-



## Disconnect the Cisco 6130 Power Connections

To disconnect the Cisco 6130 power connections, complete the following steps:



### Note

If you do not have 12 AWG wire installed, it will be necessary to completely remove the wire from the Cisco 6130 power connections and the fuse and alarm panel. You will replace these wires with a larger gauge wire later in the procedures.

- Step 1** Use a socket driver or a Phillips-head screwdriver to remove the clear cover over the Cisco 6130 power connections.
- Step 2** Disconnect the wires connecting the Cisco 6130 chassis to the fuse and alarm panel (POS RTN and NEG DC connections) as shown in Figure 6 (dual-power feed) and Figure 7 (single-power feed).

**Figure 6** Power Connections for the Cisco 6130—Dual-Power Feed

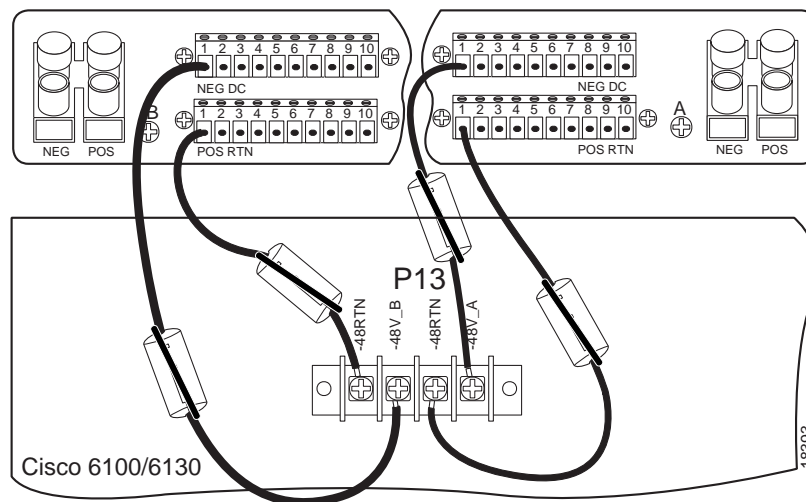

**Figure 7** Power Connections for the Cisco 6130—Single-Power Feed

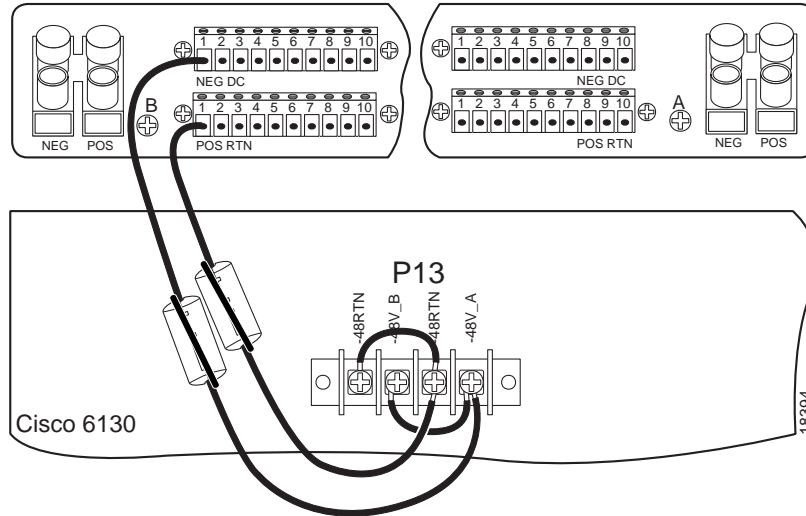

**Note** Figure 6 and Figure 7 show the wires looped through a ferrite. If you use thicker wire, it will not be necessary to loop the wire through the ferrite.

## Disconnect the Cisco 6130 Cables

Disconnect the Champ cables from the J39 and J42 connectors on the chassis backplane. Do not disconnect any of the other cables at this time.

## Remove the Cisco 6130 Chassis Ground

If you have 14 AWG copper wire connecting the Cisco 6130 chassis ground, complete the following steps to disconnect the Cisco 6130 chassis ground connection:



**Note** If you do not have 12 AWG wire installed, it will be necessary to completely remove the grounding wire. You will replace the grounding wire with a larger gauge wire later in the procedures.

- Step 1** Use a 3/16-inch flat-head screwdriver to loosen the screw on the rack.
- Step 2** Unhook the end of the copper wire that is around the screw on the rack.
- Step 3** Loosen the compression screw that is provided on the grounding lug of the Cisco 6130.
- Step 4** Remove the other end of the wire.
- Step 5** Tighten the compression screw.

## Install the New Lexan Shield

Complete the following steps to replace the existing lexan shield:

- Step 1** Use a Phillip-head screwdriver to remove the 23 backplane screws shown in Figure 8. Keep the backplane screws for future use.

**Figure 8** Backplane Screw Locations for Removing the Lexan Shield

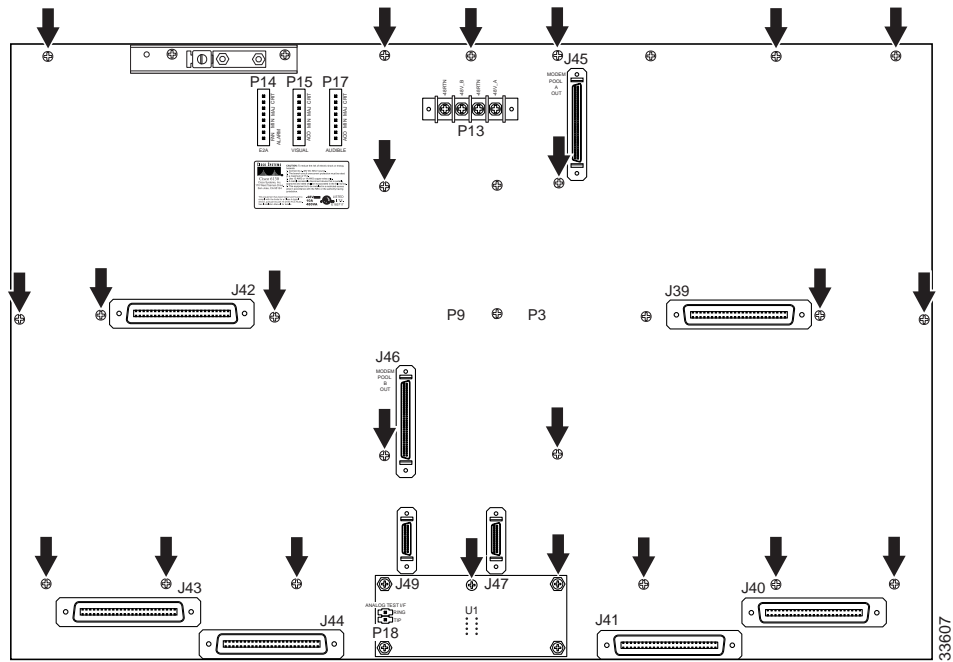

- Step 2** Carefully remove the existing lexan shield.

- Step 3** Cut the top left corner from the existing lexan shield. This will preserve the UL label, that will need to be reattached over the new lexan shield. See Figure 9 for an illustration of the cut corner.

**Figure 9** *UL Label Installation*

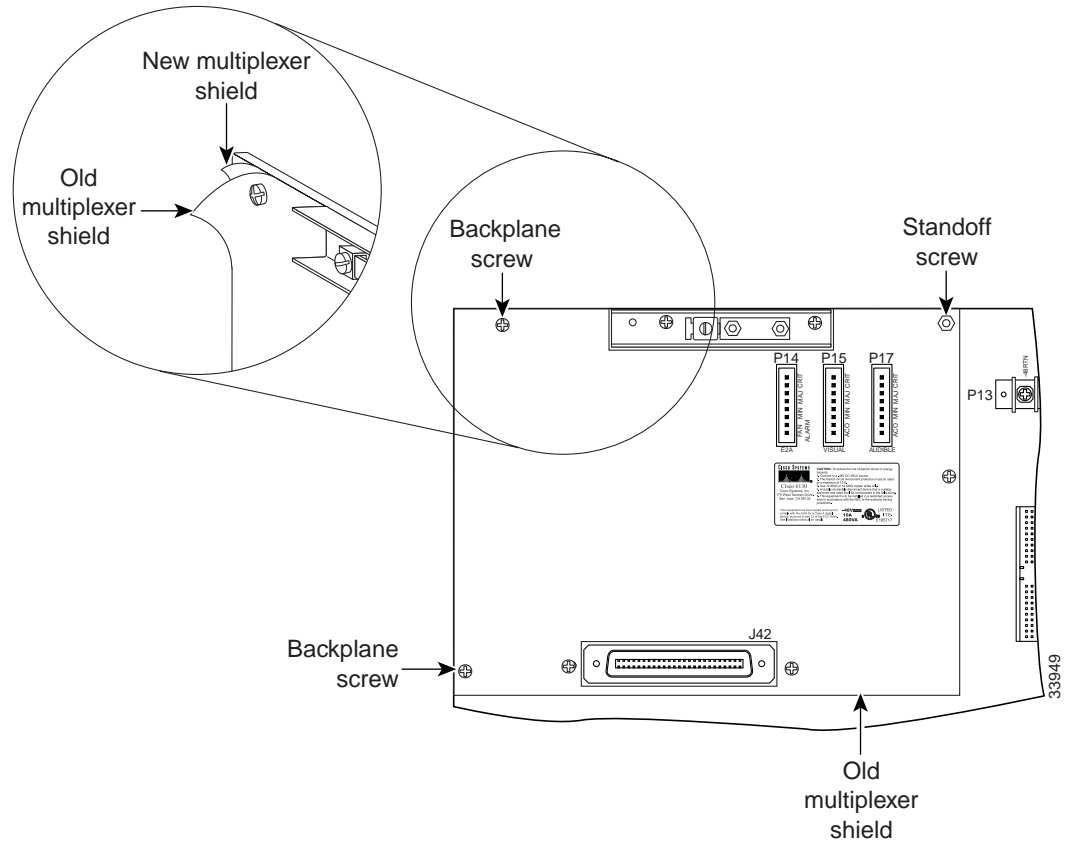

- Step 4** Place the new lexan shield over the backplane.

- Step 5** Use a Phillips-head screwdriver to reattach the 13 of the 23 backplane screws that you removed in Step 1, as shown in Figure 10.

**Figure 10** Backplane Screw Locations for Installing the Lexan Shield

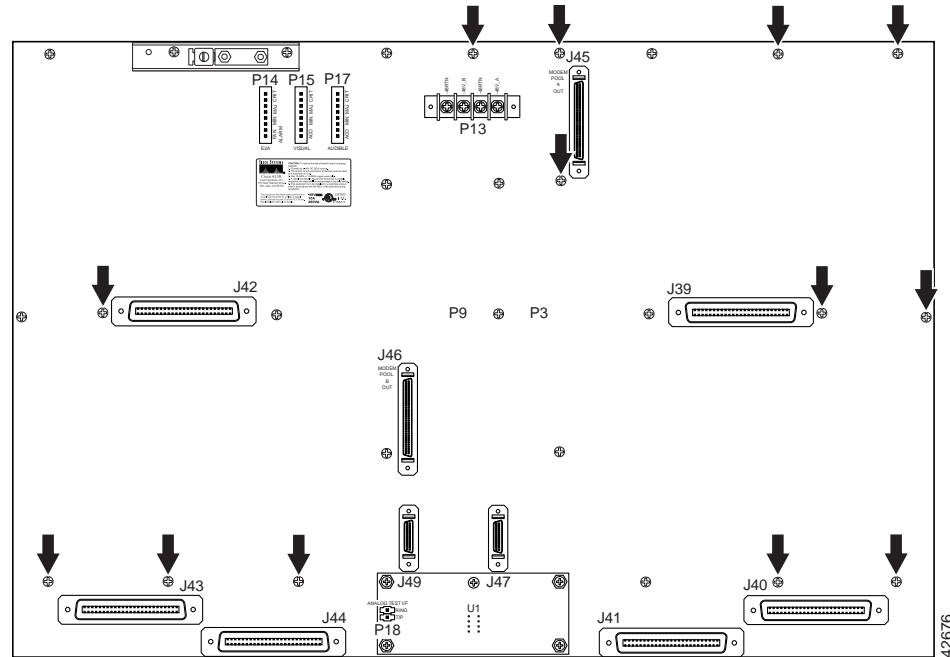

- Step 6** Place the cut-out corner of the old lexan shield over the new lexan shield, as shown in Figure 9.
- Step 7** Use a Phillips-head screwdriver and two backplane screws to attach the corner to the new lexan shield, as shown in Figure 9.
- Step 8** Use a one-quarter inch socket driver or wrench and a standoff screw to attach the corner to the new lexan shield, as shown in Figure 9. Tighten the standoff screws using the one-quarter inch socket driver or wrench.

## Ground the Cisco 6130 Chassis

Complete the following steps to connect the grounding lug on the Cisco 6130 chassis directly to the rack:

- Step 1** Verify that all paint or oxidation is removed from the rack at the point of the grounding connection.
- Step 2** Measure enough wire (12 AWG or thicker green or green with yellow stripes stranded copper wire) to connect the Cisco 6130 to the rack. (See Figure 10 for grounding wire location.)



**Note** Make sure your wire is as short as possible to make the connection.

- Step 3** Use a wire stripper to remove the casing from both ends of the wire.
- Step 4** Use a 3/16-inch flat-head screwdriver to loosen the screw on the rack.

**Step 5** Hook one end of the copper wire around the screw on the rack.

**Step 6** Tighten the rack screw over the copper wire.



**Note** You can use a lug terminal to connect the grounding wire to the rack.

**Step 7** Loosen the compression screw that is provided on the grounding lug of the Cisco 6130.

The grounding lugs are located in the upper left corner of each chassis (viewed from the rear).

**Step 8** Insert the other end of the copper wire under the compression screw.

**Step 9** Tighten the compression screw over the copper wire.



**Note** Do not ground the components in a rack by chaining them together.

The left side of Figure 11 shows how to ground the Cisco 6130 chassis.

**Figure 11** *Grounding the Cisco 6130 Chassis*

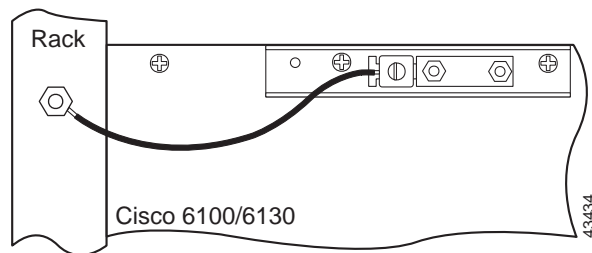

## Connect the Cisco 6130 to the Cisco 6120

Connect the one-to-two Champ cables from the Cisco 6100 (connectors J39 through J44) to the Cisco 6120 (connectors J1 through J6). Table 3 shows the corresponding Cisco 6100 and Cisco 6120 connectors when two Cisco 6120 chassis are used.

**Table 3** *Cisco 6100 and Cisco 6120 Corresponding Connectors*

Cisco 6100 Connector	First Cisco 6120 Connector	Second Cisco 6120 Connector
J39	J3	J3
J40	J1	J1
J41	J5	J5
J42	J4	J4
J43	J2	J2
J44	J6	J6

Figure 12 shows the cabling between one Cisco 6100 and two Cisco 6120 chassis in which the one-to-two cables are used.

*Figure 12 Cisco 6100 to Two Cisco 6120 Chassis Cabling Diagram with One-to-Two Cables*

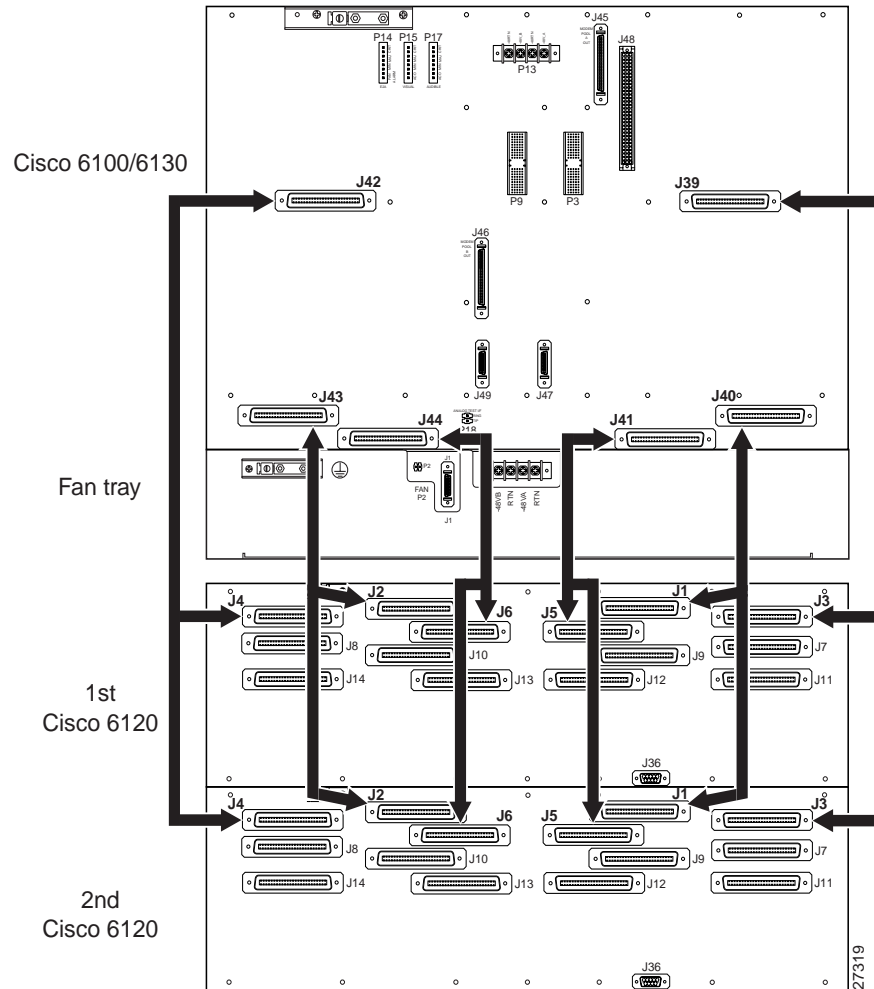

**Note** If you are intermixing xTU-C line cards, refer to the *Cisco 6130 with NI-2 Hardware Installation Guide* for cable part numbers and cabling diagrams.

## Attach the Cisco 6130 Power Connections

**Note**

---

If you do not have 12 AWG wire installed, it will be necessary to replace the wire from the Cisco 6130 power connections and the fuse and alarm panel.

---

**Caution**

---

To prevent the system from powering up, do not install the fuses at this time. If the fuses are already installed in the fuse and alarm panel, remove them. You can replace the fuses after the system is wired.

---

**Note**

---

Connect each Cisco 6130 with NI-2 system component to a separate fuse. Do not power the components in the rack by chaining them together.

---

**Step 1**

---

Reconnect the wires that connect the Cisco 6130 chassis to the fuse and alarm panel (POS RTN and NEG DC connections) as shown in Figure 6 (dual-power feed) and Figure 7 (single-power feed).

These wires were removed in the “Disconnect the Cisco 6130 Power Connections” section on page 24.

**Step 2**

Use a socket driver or a Phillips-head screwdriver to attach the clear cover over the Cisco 6130 power connections.

**Note**

---

Figure 6 and Figure 7 show the wires looped through a ferrite. If you use thicker wire, it will not be necessary to loop the wire through the ferrite. Looping the wire secures the ferrite.

---



## Install the New System I/O Card

Complete the following steps to install the new system I/O card on the chassis backplane:

- Step 1** Use a one-quarter inch socket driver or wrench to attach nine standoff screws into the locations that are shown in Figure 13. Tighten the standoff screws using the one-quarter inch socket driver or wrench.



**Caution**

Be careful when you remove the standoff screws and reinsert the screws into the screw holes on the backplane so that the backplane circuitry does not become damaged.

*Figure 13 Standoff Screw Locations for the System I/O Card Installation*

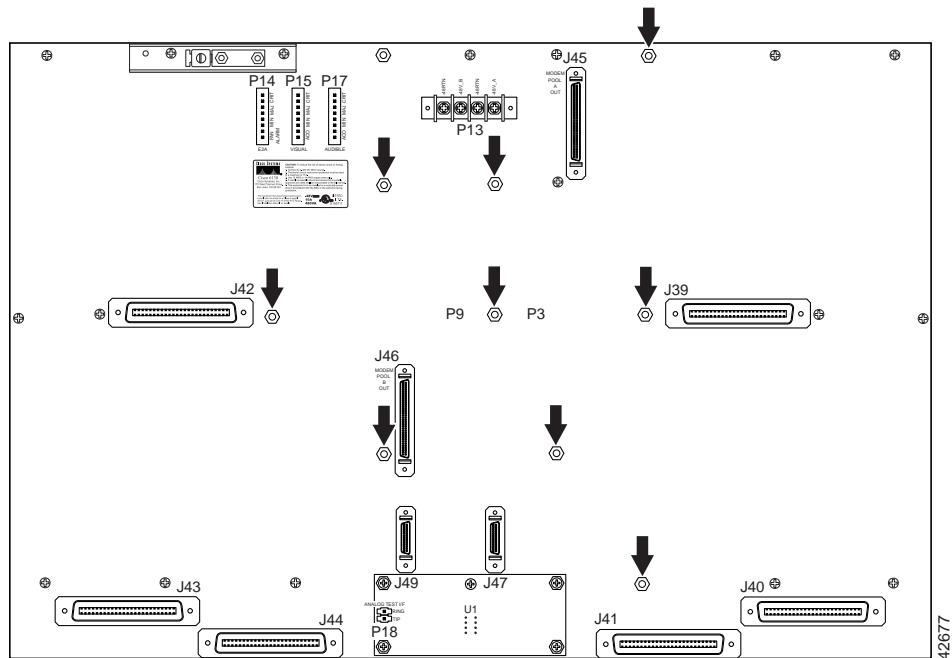

- Step 2** Hold the system I/O card vertically and align the holes on the system I/O card over the twelve standoff screws, as shown in Figure 14.

**Figure 14** System I/O Card Installation

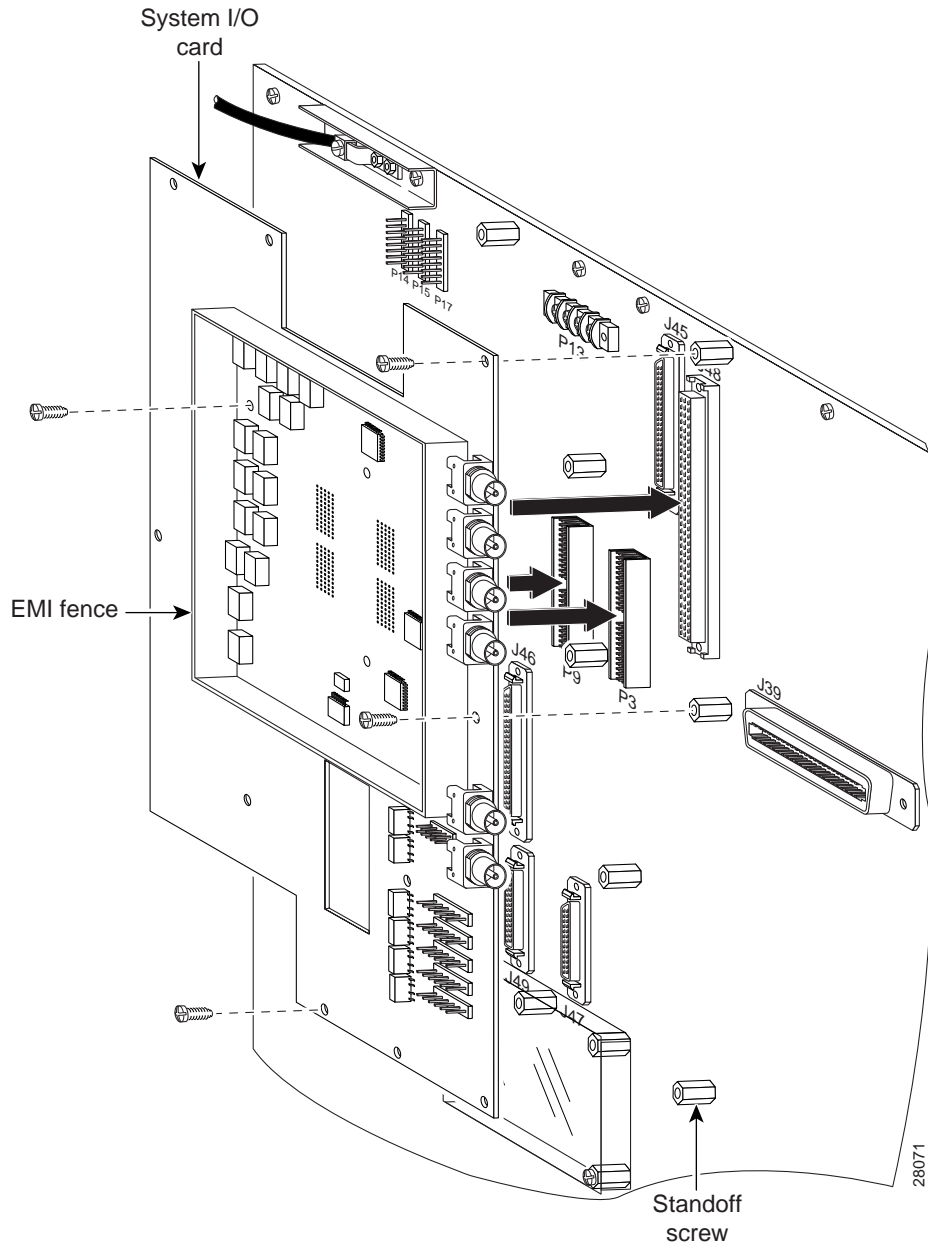

- Step 3** Carefully press the system I/O card onto the Cisco 6130 connectors P3 and P9 on the chassis backplane until the system I/O card is in place and against the standoff screws.
- Step 4** Use a Phillips-head screwdriver and four backplane screws to attach the system I/O card to the standoff screws, as shown in Figure 14.

- Step 5** Use a Phillips-head screwdriver and two backplane screws to attach the EMI cover bracket, as shown in Figure 15.

**Figure 15** EMI Cover Installation

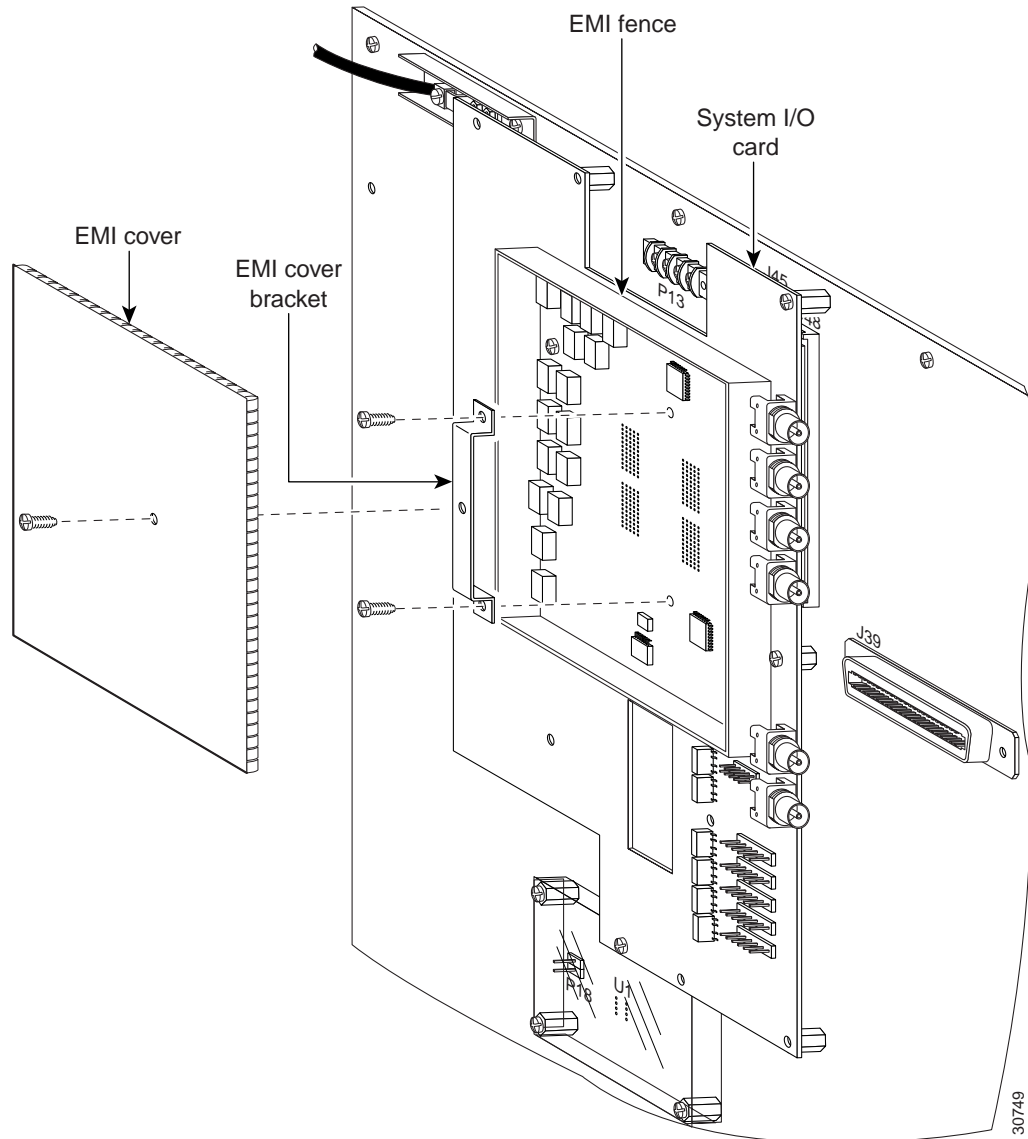

- Step 6** Attach the EMI cover on the EMI fence, as shown in Figure 15.



**Caution**

Be careful not to bend the tabs on the EMI cover when you install the cover on the EMI fence.

- Step 7** Verify that no EMI cover tabs are outside the EMI fence.
- Step 8** Use a Phillip-head screwdriver and a screw to attach the EMI cover to the EMI cover bracket, as shown in Figure 15.

- Step 9** Use a Phillips-head screwdriver and three backplane screws to attach the safety shield to the left side of the system I/O card, as shown in Figure 16. The backplane screws will screw into the existing standoff screws on the backplane.

**Figure 16** Safety Shield and ESD Shield Installation

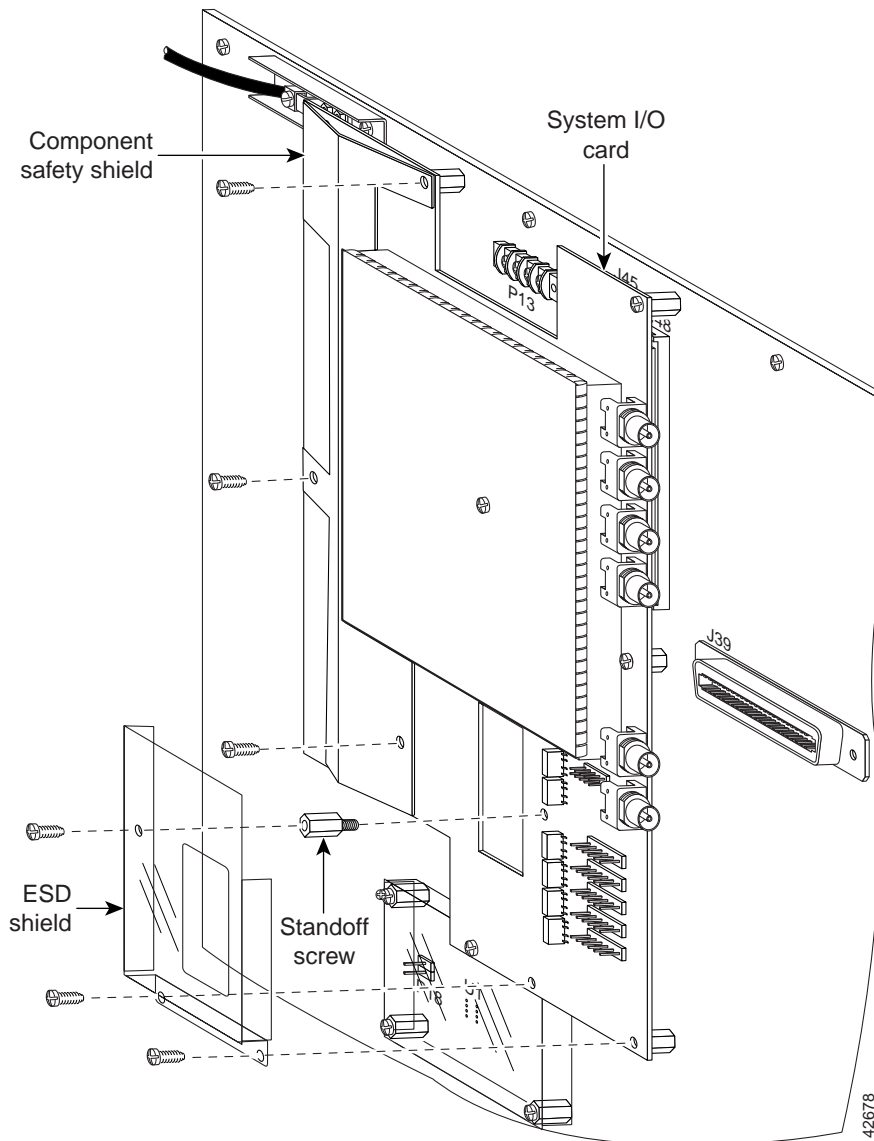

- Step 10** Use a one-quarter inch socket driver or wrench to screw a standoff screw between relays K4 and K5, as shown in Figure 16. Tighten the standoff screws using the one-quarter inch socket driver or wrench.
- Step 11** Place the ESD shield above the standoff screw that you installed in Step 10 so that the hole in the shield aligns with the standoff screw, as shown in Figure 16.
- Step 12** Use a Phillips-head screwdriver and three backplane screws to attach the plastic ESD shield to the system I/O card (see Figure 16).

## Connect the Fan Tray

Connect the fan tray alarm cable (part number 72-1912-01) between connector J1 on the fan tray and connector J49 on the Cisco 6130 chassis, as shown in Figure 17.

*Figure 17 Cabling the Fan Tray to the Cisco 6130*

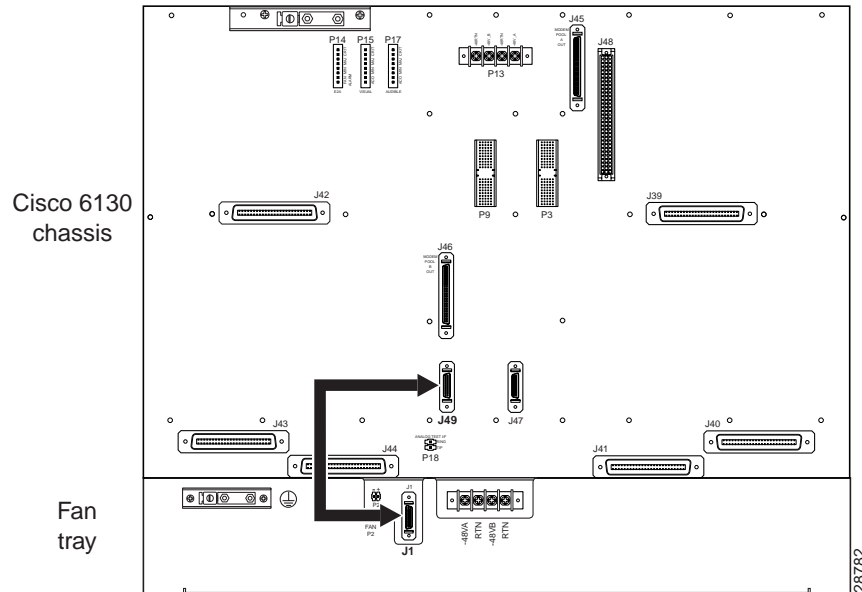

## Connect the Alarm Contacts

Five rows of wire-wrap pins are located on the right side of the system I/O card. These pins support the following alarms:

- Visual critical
- Visual major
- Visual minor
- Audible critical
- Audible major
- Audible minor
- Power module alarms
- Remote alarm cutoff
- Reserved (several pins that are reserved for future specification)

One NI-2 card in the Cisco 6130 chassis manages the alarms that are generated by the wire-wrap pins (P1 through P5). An alarm cutoff (ACO) switch, located on the NI-2 card faceplate, shuts off the audible alarms.

Figure 18 shows the location of the wire-wrap pins on the system I/O card.

**Figure 18** System I/O Card Alarm Contacts

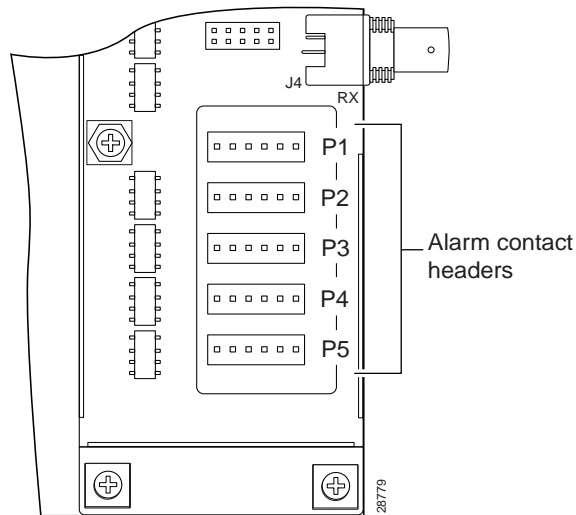

Table 4 maps the wire-wrap pins to the alarms that are supported by the NI-2 card through the Cisco 6130 chassis backplane.

**Table 4** System I/O Card Wire-Wrap Pin Mapping

PIN No.	Header P1	Header P2	Header P3	Header P4 <sup>1</sup>	Header P5
Pin 1 (left)	AUD <sup>2</sup> _CRIT <sup>3</sup> _CO <sup>4</sup>	AUD_MIN <sup>5</sup> _CO	VIS <sup>6</sup> _MAJ_CO	FAN ALARM	RX_BITS <sup>7</sup> _TIPA
Pin 2	AUD_CRIT_NO <sup>8</sup>	AUD_MIN_NO	VIS_MAJ <sup>9</sup> _NO	Reserved	RX_BITS_RINGA
Pin 3	AUD_CRIT_NC <sup>10</sup>	AUD_MIN_NC	VIS_MAJ_NC	Reserved	RX_BITS_GND/GND
Pin 4	AUD_MAJ_CO	VIS_CRIT_CO	VIS_MIN_CO	Reserved	RX_BITS_TIPB
Pin 5	AUD_MAJ_NO	VIS_CRIT_NO	VIS_MIN_NO	ACO <sup>11</sup> _NO	RX_BITS_RINGB
Pin 6 (right)	AUD_MAJ_NC	VIS_CRIT_NC	VIS_MIN_NC	ACO GND <sup>12</sup>	RX_BITS_GND/GND

1. Header P4 is used for the fan tray alarm.
2. AUD = audible.
3. CRIT = critical.
4. CO = common.
5. MIN = minimum.
6. VIS = visual.
7. RX\_BITS = receive building-integrated timing source.
8. NO = normally open.
9. MAJ = major.
10. NC = normally closed.
11. The ACO switch is located on the faceplate of the NI-2 card. This switch turns off the audible alarms that are generated by the system software.
12. GND = ground.

## Remove the DS3 STM

Complete the following steps to remove the DS3 STM from the Cisco 6130 chassis:

- 
- Step 1** Open the front cover on the Cisco 6130 chassis.
  - Step 2** Lift up on the ejector tab of the DS3 STM. This action disconnects the module from the backplane.
  - Step 3** Carefully slide the module out of the slot.
- 

## Remove the System Controller Card

Complete the following steps to remove the system controller card from the Cisco 6130 chassis:

- 
- Step 1** Lift up on the ejector tab of the system controller card. This action disconnects the card from the backplane.
  - Step 2** Carefully slide the card out of the slot.
- 

## Remove the NI-1 Card

This section provides the removal procedures for the DS3 and the OC-3c NI-1 cards.

### Removing a DS3 NI-1 Card



#### Caution

---

Proper ESD protection is required whenever you handle Cisco DSLAM equipment. Installation and maintenance personnel should be properly grounded using ground straps to eliminate the risk of ESD damage to the equipment. Cards are subject to ESD damage whenever they are removed from the chassis.

---

Complete the following steps to remove a DS3 NI-1 card from the Cisco 6130:

- 
- Step 1** Lift up on the ejector tabs of the DS3 NI-1 card. This action disconnects the card from the backplane.
  - Step 2** Carefully slide the card out of the slot.
-

## Removing an OC-3c NI-1 Card



### Caution

Proper ESD protection is required whenever you handle Cisco DSLAM equipment. Installation and maintenance personnel should be properly grounded using ground straps to eliminate the risk of ESD damage to the equipment. Cards are subject to ESD damage whenever they are removed from the chassis.

Complete the following steps to remove an OC-3c NI-1 card from the Cisco 6130:

- Step 1** Disconnect the optical fiber that is going to the transmit and receive connectors in the inset on the front panel of the OC-3c NI-1 card. See Figure 19 for the OC-3c NI-1 connection location.

*Figure 19 OC-3c NI-1 Connection*

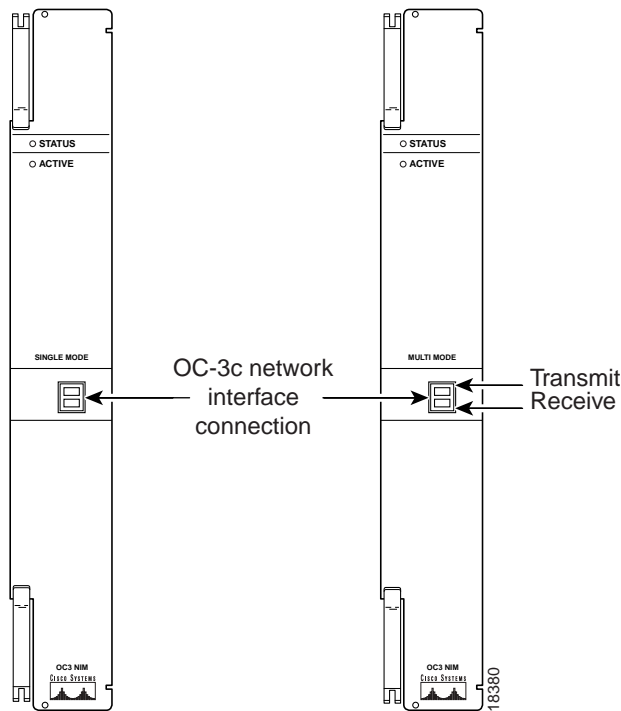

### Warning

Because invisible laser radiation may be emitted from the aperture of the OC-3 NI-2 card optical interface port when no optical cable is connected, avoid exposure to laser radiation and do not stare into an open aperture.

- Step 2** Pull the fiber through to the front of the chassis.
- Step 3** Lift up on the ejector tabs of the OC-3c NI-1 card. This action disconnects the card from the backplane.
- Step 4** Carefully slide the card out of the slot.



## Verify Correct Fuses

Use Table 5 to calculate the minimum fuse rating that is necessary for each of your Cisco 6130 with NI-2 system components. Verify that your system is using the minimum fuse rating for each component that is wired to the fuse and alarm panel.

**Note**

The power rating label that is supplied on the rear of each chassis and fan tray indicates the maximum fuse value for the chassis or the fan tray.

**Table 5** Fuse Calculation for the Cisco 6130 with NI-2 System Components

Component	Instructions	Calculation
<b>Cisco 6130 Chassis<sup>1,2</sup></b>		
1a	If you are using 4xDMT-2 line cards, multiply 16.5W by the total number of line cards in the Cisco 6130.	
1b	If you are using 4xflexi line cards, multiply 13.5W by the total number of line cards in the Cisco 6130.	
1c	If you are using 4xSDSL line cards, multiply 9W by the total number of line cards in the Cisco 6130.	
1d	Add the amounts for lines 1a through 1c.	
2	Enter 33.5 for the NI-2 card.	
3	Add lines 1d and 2. This is the typical power required for the Cisco 6130.	
4	Divide line 3 by 48. This is the nominal current for the Cisco 6130.	
5	Multiply line 4 by 1.25. This is the minimum fuse rating needed to operate the Cisco 6130 in your system.	
<b>Fan Tray</b>		
6	A 1.25A fuse is required for each fan tray that is wired to the fuse and alarm panel. A fan tray must be installed under a Cisco 6130 chassis.	

- For a Direct Connect configuration, the maximum number of Cisco 6130 chassis is two per rack.
- Complete this section for each subtending host.

## Apply Power

Complete the following steps to apply power to the Cisco 6130 with NI-2 system:

- 
- Step 1** Verify that there are no cards installed in any of the Cisco 6130 chassis.
- Step 2** Apply power to the system with one of the following methods:
- Install the fuses in the fuse and alarm panel
  - Reinsert the fuses in the fuse and alarm panel, if you removed them in the “Remove the Power” section on page 19.
  - Turn on the breakers in the fuse and alarm panel

**Caution**

---

If the power connections are improperly connected and power is applied while the cards are installed, the cards and chassis could be damaged.

---

- Step 3** Verify that the power connections from the Cisco 6130 to the fuse and alarm panel are wired as shown in Figure 6 or Figure 7.
- Step 4** Check the polarity of the –48 VDC connections to each chassis by attaching a voltmeter with the minus lead on –48 RTN and the plus lead on –48 V\_A. Ensure that the meter reads between –36 VDC and –60 VDC. If your voltmeter shows a positive voltage, the power inputs might be reversed. If the voltmeter shows a negative voltage that is out of the –36 VDC to –60 VDC range, check the power supply for failure or check for a blown fuse in the fuse and alarm panel.
- 

## Verify Fan Tray Operation

Verify that the fans are operational by locating the LED on the front of each fan. If the LED is

- Green—The fan is operational.
- Not green—The fan is not operational and the fan tray is in alarm mode. Refer to the *Cisco 6130 with NI-2 Hardware Installation Guide* for corrective action.

**Caution**

---

It is important that the Cisco 6130 cooling fans run continuously.

---

**Warning**

---

**The power supply circuitry for the Cisco DSLAM equipment can constitute an energy hazard. Before you install or replace the equipment, remove all jewelry (including rings, necklaces, and watches). Metal objects can come into contact with exposed power supply wiring or circuitry inside the DSLAM equipment. This could cause the metal objects to heat up and cause serious burns or weld the metal object to the equipment.**

---

**Warning**

---

**Do not reach into a vacant slot or chassis while you install or remove a line card or a fan. Exposed circuitry could constitute an energy hazard.**

---

## Install the NI-2 Card

**Caution**

---

Proper ESD protection is required each time you handle Cisco DSLAM equipment. Installation and maintenance personnel should be properly grounded using ground straps to eliminate the risk of ESD damage to the equipment. Cards are subject to ESD damage each time they are removed from the chassis.

---

**Caution**

Installing the cards in the chassis with the power leads reversed can damage the cards.

**Warning**

The power supply circuitry for the Cisco DSLAM equipment can constitute an energy hazard. Before you install or replace the equipment, remove all jewelry (including rings, necklaces, and watches). Metal objects can come into contact with exposed power supply wiring or circuitry inside the DSLAM equipment. This could cause the metal objects to heat up and cause serious burns or weld the metal object to the equipment.

**Warning**

Do not reach into a vacant slot or chassis while you install or remove a line card or a fan. Exposed circuitry could constitute an energy hazard.

**Note**

All cards must be fully seated in the chassis. A push on the faceplate of each card is required for the card to be fully seated.

Complete the following steps to install the NI-2 card in the Cisco 6130. It is important that you accomplish each step completely before moving on to the next step.

- Step 1** Inspect the NI-2 card. Verify that the daughterboard is fully seated on the main board.
- Step 2** Verify that slots 10 and 11 of the Cisco 6130 have no bent pins.
- Step 3** Vertically align the card edge with the card guides at the top and bottom of slot 10 on the Cisco 6130.
- Step 4** Lift up on the ejector tabs and gently apply pressure to the bottom of the faceplate while pushing the card into the slot.
- Step 5** Push on the faceplate of each card to fully seat the card.
- Step 6** Press down on the ejector tabs to secure the card and connect it to the backplane.
- Step 7** Lock both NI-2 card locking tabs.

Use a flat-head screwdriver to turn the locking tab so that it overlaps the NI-2 card to prevent inadvertent dislodging, as shown in Figure 20.

**Figure 20** Locking the NI-2 Card

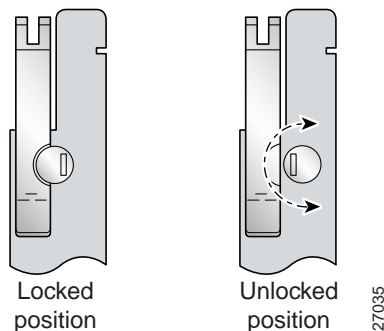

- Step 8** Verify that the STATUS LEDs on all cards are solid green (where applicable).  
This self-test procedure takes several minutes. If the STATUS LEDs are not green after the self-test, refer to the *Cisco 6130 with NI-2 Hardware Installation Guide* for troubleshooting procedures.
- Step 9** Perform a software update if the STATUS LEDs on the xTU-C line cards are flashing.  
Refer to the *Configuration Guide for Cisco DSLAMs with NI-2* for software upgrade procedures.
- 

## Install Blank Faceplate for the STM and the System Controller Card

Complete the following steps to install blank faceplates in the DS3 STM and system controller card slots:

- Step 1** Vertically align the blank faceplate edge with the card guides at the top and bottom of slot 9 for the STM.
- Step 2** Lift up on the ejector tab and gently apply pressure to the bottom of the faceplate while pushing the blank faceplate into the slot.
- Step 3** Push on the faceplate to fully seat the blank faceplate.
- Step 4** Press down on the ejector tab to secure the faceplate.
- Step 5** Repeat Step 1 through Step 4 for the system controller card in slot 12.
- 

## Install the xTU-C Line Cards



### Caution

Proper ESD protection is required each time you handle Cisco DSLAM equipment. Installation and maintenance personnel should be properly grounded using ground straps to eliminate the risk of ESD damage to the equipment. Cards are subject to ESD damage each time they are removed from the chassis.

---



### Caution

Installing the cards in the chassis with the power leads reversed can damage the cards.

---



### Warning

The power supply circuitry for the Cisco DSLAM equipment can constitute an energy hazard. Before you install or replace the equipment, remove all jewelry (including rings, necklaces, and watches). Metal objects can come into contact with exposed power supply wiring or circuitry inside the DSLAM equipment. This could cause the metal objects to heat up and cause serious burns or weld the metal object to the equipment.

---



### Warning

Do not reach into a vacant slot or chassis while you install or remove a line card or a fan. Exposed circuitry could constitute an energy hazard.

---



**Note** All cards must be fully seated in the chassis. A push on the faceplate of each card is required for the card to be fully seated.

Complete the following steps to install the xTU-C line cards in the Cisco 6130. It is important that you accomplish each step completely before moving on to the next step.

- Step 1** Vertically align the line card edge with the line card guides at the top and bottom of slot 1 on the Cisco 6130.
- Step 2** Lift up on the ejector tab and gently apply pressure to the bottom of the faceplate while pushing the line card into the slot.
- Step 3** Push on the faceplate of each line card to fully seat the line card.
- Step 4** Press down on the ejector tab to secure the line card and connect it to the backplane.
- Step 5** Lock the xTU-C line cards, as necessary.



**Note** It is not necessary to lock the xTU-C line cards.

Use a flat-head screwdriver to turn the locking tab so that it overlaps the xTU-C line card to prevent inadvertent dislodging, as shown in Figure 21.

**Figure 21** Locking the xTU-C Line Card

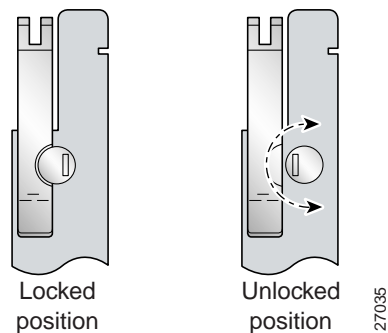

- Step 6** Install the remaining xTU-C line cards using the same procedure.  
The xTU-C line cards are installed in slots 1 through 8, 13 through 28, and 31 through 38.
- Step 7** Verify that the STATUS LEDs on all line cards are solid green (where applicable).  
This self-test procedure takes several minutes. If the STATUS LEDs are not green after the self-test, refer to the *Cisco 6130 with NI-2 Hardware Installation Guide* for troubleshooting procedures.



**Note** Blank faceplates should occupy any empty slots in the Cisco 6130. The blank faceplate installation is similar to the line card installation.

## Connect the NI-2 Card to the Network

This section provides installation procedures for the DS3 and OC-3 network connections.

### DS3 Network Connection Installation

Complete the following steps to connect the DS3 NI-2 card to the network:

- Step 1** Verify that the DS3 NI-2 card is installed in slot 10 of the Cisco 6130 chassis to ensure that the DS3 NI-2 card connections are active.

The DS3 NI-2 card connections are on the system I/O card, which is located on the backplane of the Cisco 6130 chassis. These connections attach to the ATM switch. Two 75-ohm DS3 Bayonet-Neill-Concelman (BNC) connectors are provided for DS3 transmit (J14) and receive (J12). See Figure 22 for the location of the DS3 BNC connectors.

**Figure 22** DS3 NI-2 Connection Locations

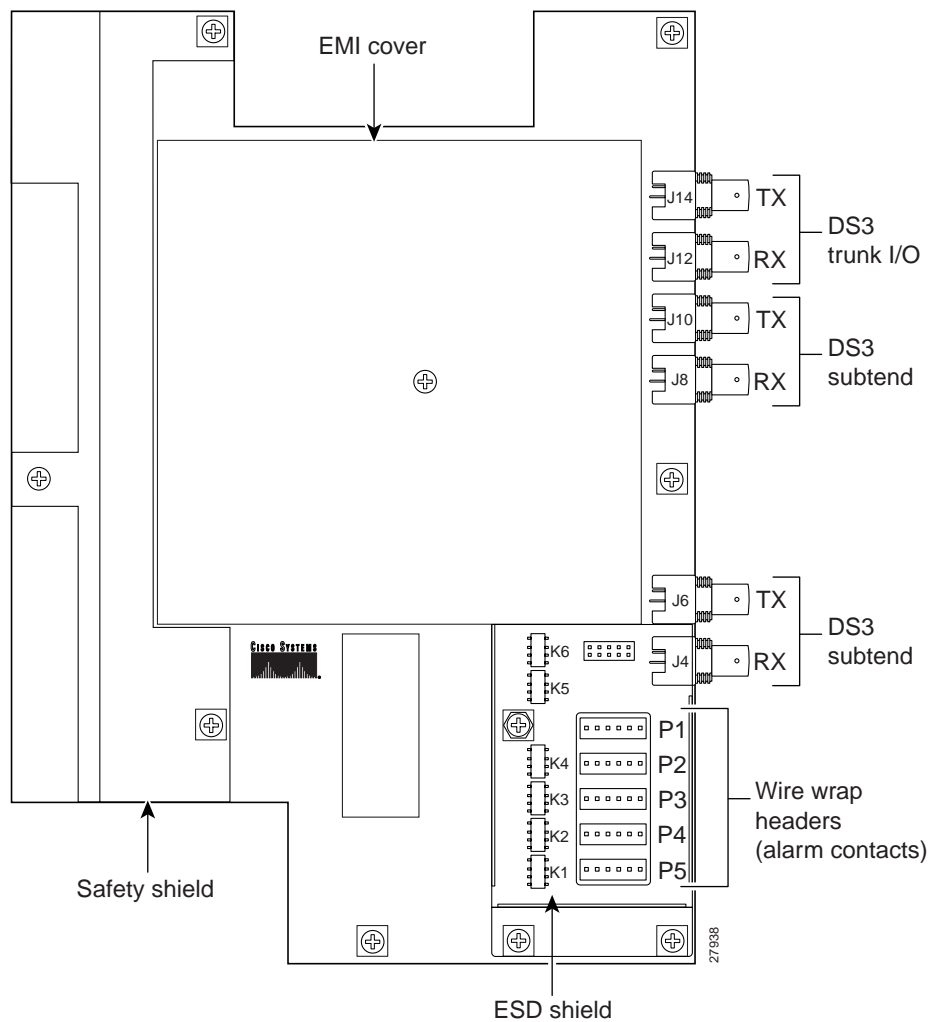

- Step 2** Attach one end of a coaxial cable (type 734A, type 735A, or equivalent) to the transmit DS3 BNC connector (J14) for the system I/O card on the chassis backplane.

- Step 3** Attach the end of the cable that you used in Step 2, which originates at the transmit DS3 BNC connector, to the ATM switch.
- Step 4** Attach one end of a coaxial cable (type 734A, type 735A, or equivalent) to the receive DS3 BNC connector (J12) for the system I/O card on the Cisco 6130 backplane.
- Step 5** Attach the end of the cable that you used in Step 4, which originates at the receive DS3 BNC connector, to the ATM switch.
- 

### OC-3 Network Connection Installation

Complete the following steps to connect the OC-3 NI-2 card to the network:



**Warning**

---

**Do not stare into the beam or view it directly with optical instruments.**

---

- Step 1** Verify that the OC-3 NI-2 card is in slot 10 of the Cisco 6130 chassis.
- Step 2** Pull the OC-3 NI-2 card transmit and receive cables from the ATM switch through the 1 RU of space between the fan tray and the POTS splitter.

- Step 3** Attach the receive optical fiber to the transmit connector in the inset on the faceplate of the OC-3 NI-2 card (trunk 1 interface connector TX). See Figure 23 for the OC-3 network interface connection location.

**Figure 23** OC-3 Network Interface Connection

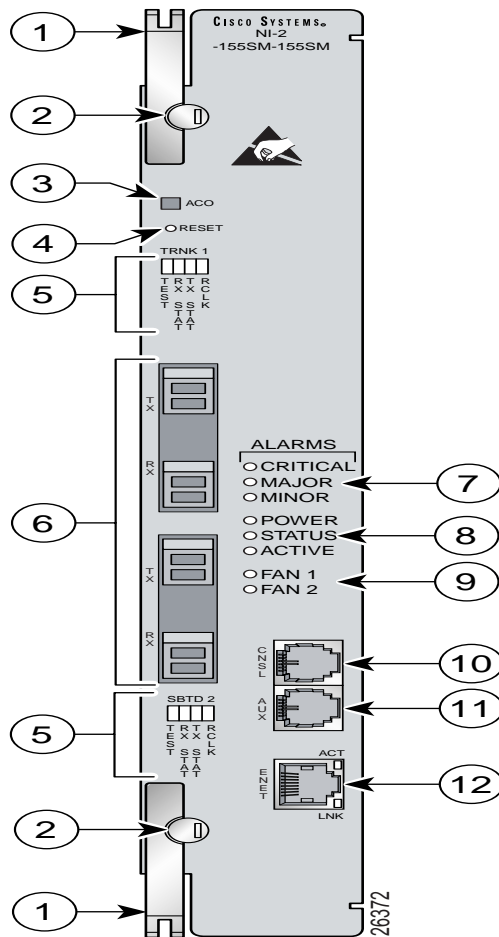

The transmit connector is the one closest to the top of the faceplate. The receive connector is closest to the bottom of the faceplate. The connector IDs are silkscreened inside the inset.

- Step 4** Attach the transmit optical fiber to the receive connector in the inset on the faceplate of the OC-3 NI-2 card (trunk 1 interface connector RX). See Figure 23 for the OC-3 network interface connection location.
- Step 5** Allow enough slack in the cable so that the fan tray can be opened and the fans can be maintained.
- Step 6** Coil the fiber loosely within the 1 RU of space to take out slack.



## Reconnect the Subtended Network Configuration

The following sections provide installation procedures for the DS3 and OC-3 subtended network configuration.



**Note**

For information on a subtended network configuration, see the “Subtended Network Configuration Overview” section on page 9.

### Cable the DS3 Subtending Network Configuration

Coaxial connections for DS3 cabling are located on the system I/O card. The transmit and receive DS3 BNC connectors on the subtending host chassis system I/O card are connected to the transmit and receive DS3 BNC connectors on the subtended node chassis system I/O card.



**Note**

The system I/O card BNC cables are not provided by Cisco Systems, Inc.

Complete the following steps to cable the system I/O card for subtending:

- Step 1** On the subtending host chassis backplane, attach one end of a BNC cable to the transmit DS3 BNC connector (TX1) on the system I/O card.
- Step 2** On the subtended chassis backplane, attach the end of the BNC cable used in Step 1 to the receive DS3 BNC connector (RX) on the system I/O card.
- Step 3** Repeat Steps 1 and 2 for each connection between a subtending host chassis and a subtended node chassis. If you have one subtending host chassis with two subtending node chassis, the second subtending node chassis connects to the TX2 and RX2 DS3 BNC connectors on the system I/O card.

Table 6 lists the connectors and their designations on the system I/O card.

**Table 6 DS3 Connector Designations**

DS3 Connector	System I/O Card Designation
<b>Trunk 1</b>	
Transmit	J14
Receive	J12
<b>Subtend 2</b>	
Transmit	J10
Receive	J8
<b>Subtend 3</b>	
Transmit	J6
Receive	J4

Figure 24 shows the cabling for a DS3 subtending network configuration.

**Figure 24** Cabling for DS3 Subtending Configuration

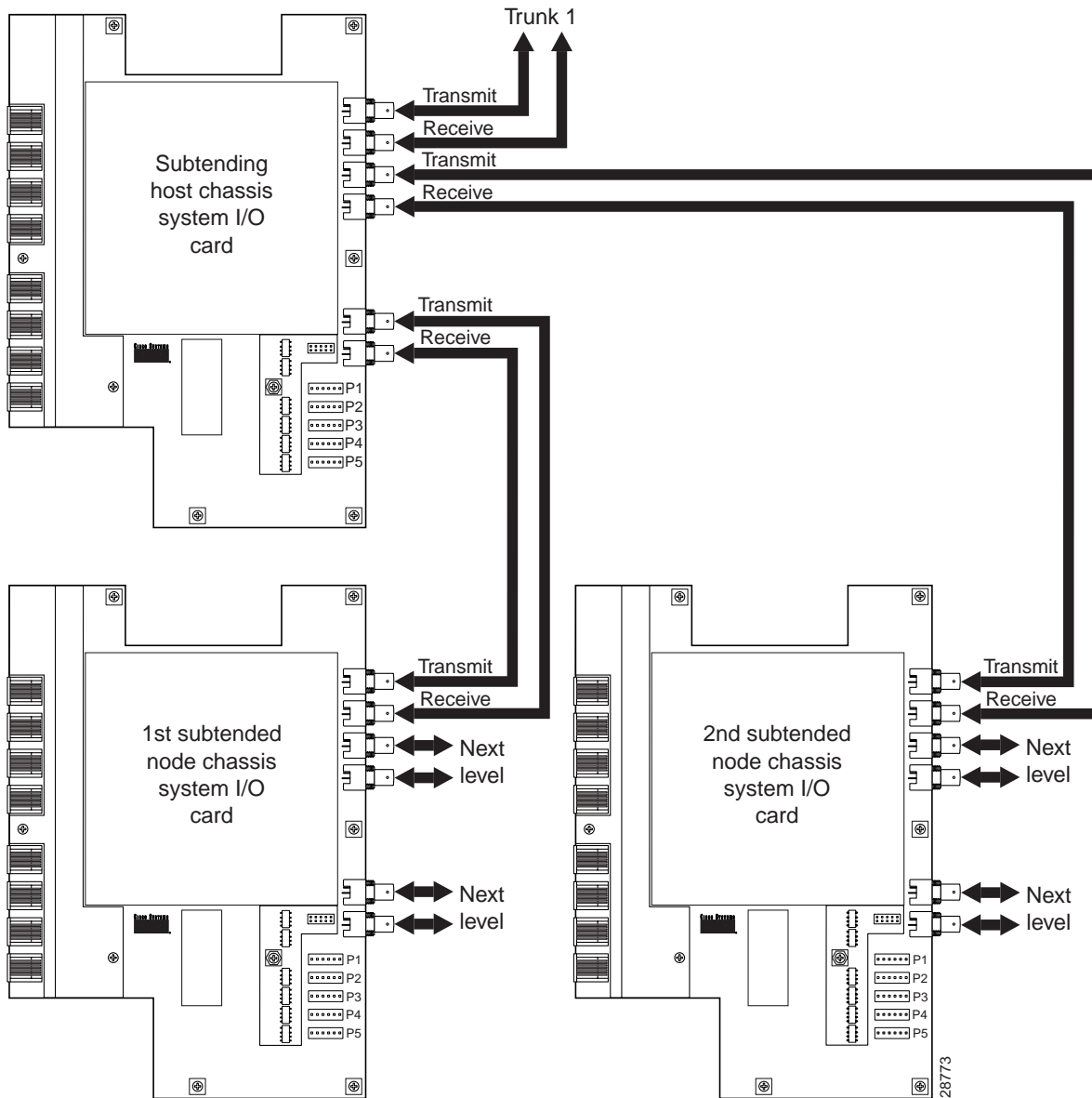

### Cable the OC-3 Subtending Network Configuration

For OC-3 subtending, the connections are made from the front of the subtending host chassis and the subtend OC-3 NI-2 card. To cable the Cisco 6100 with NI-2 system for OC-3 subtending, complete the following steps:

- Step 1** Locate the trunk transmit (top) and receive ports on the front of the OC-3 NI-2 card.
- Step 2** Connect the OC-3 fiber-optic cable from the subtending host chassis transmit port on the OC-3 NI-2 card to the receive port on the subtended node chassis OC-3 NI-2 card.

- Step 3** Connect the OC-3 fiber-optic cable from the subtending host chassis receive port on the OC-3 NI-2 card to the transmit port on the subtended node chassis OC-3 NI-2 card.

Figure 25 shows the subtending connections between two Cisco 6130 with NI-2 system chassis.

*Figure 25 Cabling Diagram for OC-3 Subtending*

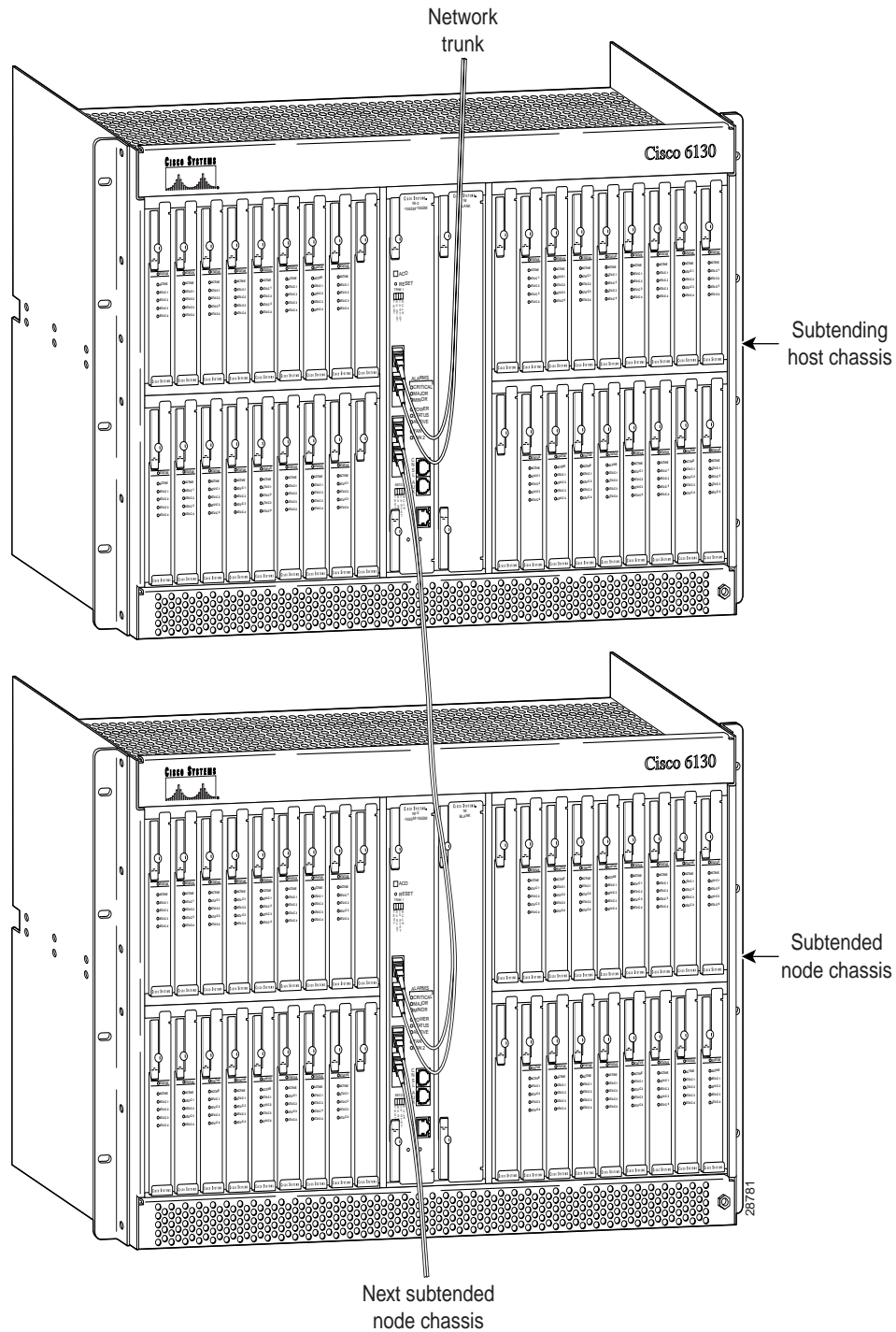

## Connect the Software Management System to the NI-2 Card

Connect both the 10BaseT RJ-45 port on the NI-2 card (ENET) and the Sun SPARCstation running the CDM management application to an Ethernet so that the Cisco 6130 and the management station can communicate.



Warning

The ports labeled "ENET," "CNSL," and "AUX" are safety extra-low voltage (SELV) circuits. SELV circuits should be connected only to other SELV circuits. Because the DSL circuits are treated like telephone-network voltage, avoid connecting the SELV circuit to the telephone network voltage (TNV) circuits.



Timesaver

Cisco recommends that you label each data cable at both ends to identify its destination.

## Connect a Console Terminal

Connect a VT100-compatible terminal to the system console port on the NI-2 card (CNSL). Connect the terminal to a power source and set it up using the values that are shown in Table 7.



Warning

The ports labeled "ENET," "CNSL," and "AUX" are SELV circuits. SELV circuits should be connected only to other SELV circuits. Because the DSL circuits are treated like telephone-network voltage, avoid connecting the SELV circuit to the TNV circuits.

*Table 7 Terminal Settings*

Baud rate	9600 (transmit and receive)
Character size	8 bits
Parity	None
Stop bits	1
Xon/Xoff	Hardware busy

## Connect the Auxiliary Port



Note

This step is optional.

Connect a terminal, a modem, or another serial device to the RJ-45 auxiliary port on the NI-2 card (AUX).



Warning

The ports labeled "ENET," "CNSL," and "AUX" are SELV circuits. SELV circuits should be connected only to other SELV circuits. Because the DSL circuits are treated like telephone-network voltage, avoid connecting the SELV circuit to the TNV circuits.



Timesaver

---

Cisco recommends that you label each data cable at both ends to identify its destination.

---

## Complete Software Configuration and Support Commands

For Cisco IOS software configuration information and support, refer to the *Configuration Guide for Cisco 6000 Family DSLAMs with NI-2* and to the *Command Reference for Cisco 6000 Family DSLAMs with NI-2*.

When you turn on the Cisco 6130 for the first time, an interactive dialog called the System Configuration Dialog appears on the console screen. The System Configuration Dialog guides you through the initial configuration process.

After you have completed your system configuration, you must enter the following commands on the console command line to initialize the converted Cisco 6130 with NI-2 system:

```
DSLAM> enable
Password:(enter your password)
DSLAM # configure terminal
DSLAM(config)# service internal
DSLAM(config)# exit
DSLAM # ni2-upgrade
DSLAM # configure terminal
DSLAM(config)# no service internal
DSLAM(config)# exit
DSLAM #
```

## Load the Subscriber Information into the NI-2 Card

After the utility successfully completes, you need to use FTP to transfer the files from the computer on which you ran the utility to the NI-2, as follows:

- 
- Step 1** Log in to the system console port and invoke the enable mode by entering enable at the prompt, and then your password:
- ```
>enable
Password: (enter your password)
```
- Step 2** Copy the IOS config file from the source to the startup-config of the NI-2 card, by responding to the following commands after the enable prompts (#):
- ```
#copy tftp startup-config
#Address or name of remote host [ ]? [source IP]

Enter the address or name of the new configuration (.cfg) file.
#Destination filename [ ]? [source path and filename]

Enter the source path and filename, such as /tftpboot/source.cfg
```
- Step 3** Reload the system by entering
- ```
#reload
```
- The >Rommon prompt displays.

**Step 4** Reboot the system by entering:

```
>boot
```

After you reboot the system, error checking begins. Any errors display on the screen as the system detects them. If the NI-2 card does not have the correct node software, you must reboot with the correct node software.

The NI-2 config file opens after you restart the system. The configuration data from your NI-1 configuration file (NSS) should be in the NI-2 card IOS configuration file.

---

## Install the New Front Cover

The front cover on the existing Cisco 6130 with NI-1 chassis is not deep enough to accommodate the NI-2 card. Consequently, the existing front cover must be replaced with the new, deeper front cover. Complete the following steps to replace the existing front cover with a new front cover:

---

**Step 1** Lift out and up on the existing front cover to remove it from the chassis.

**Step 2** Hold the new front cover, front facing you, and attach the hooks to the bottom left and right corner of the chassis.

---

## Close the Rear Cover

Complete the following steps to close the optional rear cover:

---

**Step 1** Lift the two latches on the rear cover (as shown in Figure 26) as you close the rear cover. The rear cover closes left to right (seen from the rear of the chassis).

*Figure 26 Securing the Rear Cover with the Latches*

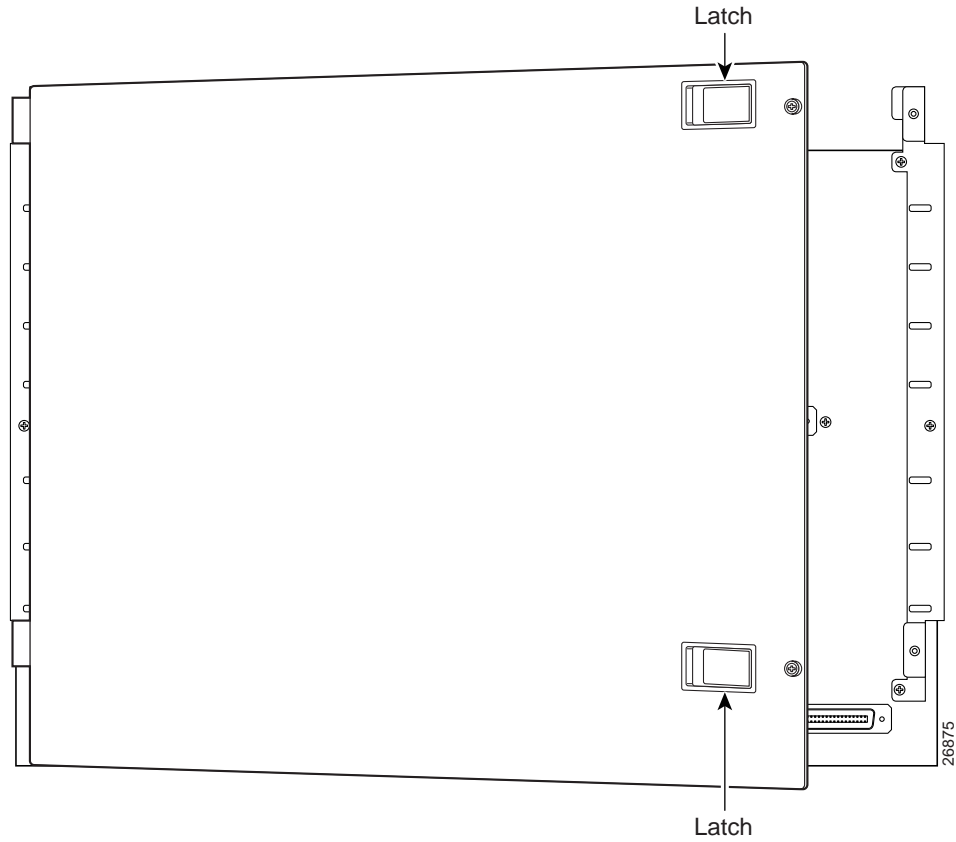

**Step 2** Release the latches after the rear cover is in place.

- Step 3** Align the two thumbscrews that are located on the rear cover with two thumbscrew fasteners on the bracket (see Figure 27). Tighten the thumbscrews to secure the rear cover.

*Figure 27 Securing the Rear Cover with Two Thumbscrews*

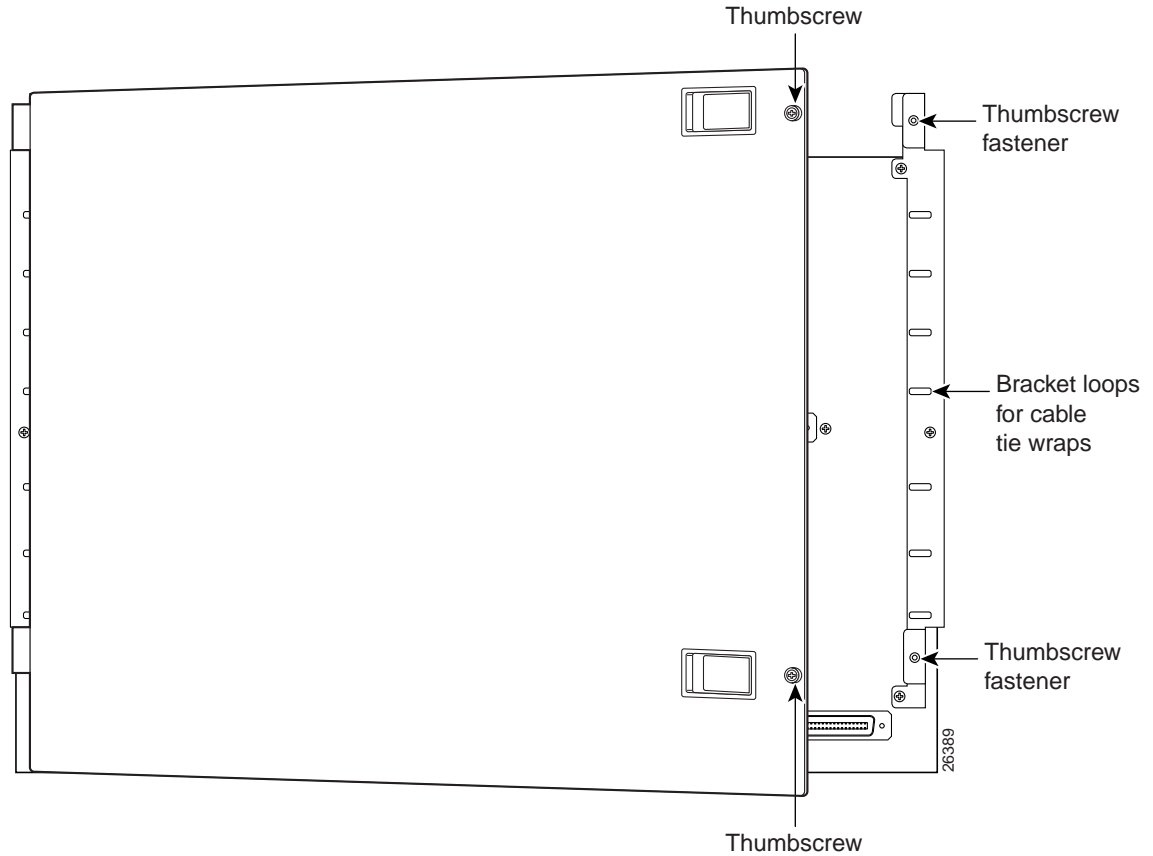

## Run the ViewRunner to CDM Migration Utility

Refer to the *ViewRunner for HP OpenView to Cisco DSL Manager Migration Utility Note* for the procedures necessary to convert subscribers from the ViewRunner management software to CDM.

## Related Documentation

A complete list of all DSL product related documentation is available on the World Wide Web at [http://www.cisco.com/univercd/cc/td/doc/product/dsl\\_prod/index.htm](http://www.cisco.com/univercd/cc/td/doc/product/dsl_prod/index.htm)



# Obtaining Documentation

The following sections provide sources for obtaining documentation from Cisco Systems.

## World Wide Web

You can access the most current Cisco documentation on the World Wide Web at <http://www.cisco.com>, <http://www-china.cisco.com>, or <http://www-europe.cisco.com>.

## Documentation CD-ROM

Cisco documentation and additional literature are available in a CD-ROM package, which ships with your product. The Documentation CD-ROM is updated monthly. Therefore, it is probably more current than printed documentation. The CD-ROM package is available as a single unit or as an annual subscription.

## Ordering Documentation

Registered CCO users can order the Documentation CD-ROM and other Cisco Product documentation through our online Subscription Services at <http://www.cisco.com/cgi-bin/subcat/kaojump.cgi>.

Nonregistered CCO users can order documentation through a local account representative by calling Cisco's corporate headquarters (California, USA) at 408 526-4000 or, in North America, call 800 553-NETS (6387).

# Obtaining Technical Assistance

Cisco provides Cisco Connection Online (CCO) as a starting point for all technical assistance. Warranty or maintenance contract customers can use the Technical Assistance Center. All customers can submit technical feedback on Cisco documentation using the web, e-mail, a self-addressed stamped response card included in many printed docs, or by sending mail to Cisco.

## Cisco Connection Online

Cisco continues to revolutionize how business is done on the Internet. Cisco Connection Online is the foundation of a suite of interactive, networked services that provides immediate, open access to Cisco information and resources at anytime, from anywhere in the world. This highly integrated Internet application is a powerful, easy-to-use tool for doing business with Cisco.

CCO's broad range of features and services helps customers and partners to streamline business processes and improve productivity. Through CCO, you will find information about Cisco and our networking solutions, services, and programs. In addition, you can resolve technical issues with online support services, download and test software packages, and order Cisco learning materials and merchandise. Valuable online skill assessment, training, and certification programs are also available.

Customers and partners can self-register on CCO to obtain additional personalized information and services. Registered users may order products, check on the status of an order and view benefits specific to their relationships with Cisco.

You can access CCO in the following ways:

- WWW: [www.cisco.com](http://www.cisco.com)
- Telnet: [cco.cisco.com](http://cco.cisco.com)
- Modem using standard connection rates and the following terminal settings: VT100 emulation; 8 data bits; no parity; and 1 stop bit.
  - From North America, call 408 526-8070
  - From Europe, call 33 1 64 46 40 82

You can e-mail questions about using CCO to [cco-team@cisco.com](mailto:cco-team@cisco.com).

## Technical Assistance Center

The Cisco Technical Assistance Center (TAC) is available to warranty or maintenance contract customers who need technical assistance with a Cisco product that is under warranty or covered by a maintenance contract.

To display the TAC web site that includes links to technical support information and software upgrades and for requesting TAC support, use [www.cisco.com/techsupport](http://www.cisco.com/techsupport).

To contact by e-mail, use one of the following:

| Language         | E-mail Address                                                   |
|------------------|------------------------------------------------------------------|
| English          | <a href="mailto:tac@cisco.com">tac@cisco.com</a>                 |
| Hanzi (Chinese)  | <a href="mailto:chinese-tac@cisco.com">chinese-tac@cisco.com</a> |
| Kanji (Japanese) | <a href="mailto:japan-tac@cisco.com">japan-tac@cisco.com</a>     |
| Hangul (Korean)  | <a href="mailto:korea-tac@cisco.com">korea-tac@cisco.com</a>     |
| Spanish          | <a href="mailto:tac@cisco.com">tac@cisco.com</a>                 |
| Thai             | <a href="mailto:thai-tac@cisco.com">thai-tac@cisco.com</a>       |

In North America, TAC can be reached at 800 553-2447 or 408 526-7209. For other telephone numbers and TAC e-mail addresses worldwide, consult the following web site:  
<http://www.cisco.com/warp/public/687/Directory/DirTAC.shtml>.

## Documentation Feedback

If you are reading Cisco product documentation on the World Wide Web, you can submit technical comments electronically. Click **Feedback** in the toolbar and select **Documentation**. After you complete the form, click **Submit** to send it to Cisco.

You can e-mail your comments to [bug-doc@cisco.com](mailto:bug-doc@cisco.com).

To submit your comments by mail, for your convenience many documents contain a response card behind the front cover. Otherwise, you can mail your comments to the following address:

Cisco Systems, Inc.  
Document Resource Connection  
170 West Tasman Drive  
San Jose, CA 95134-9883

We appreciate and value your comments.

---

This document is to be used in conjunction with the documents listed in the "Related Documentation" section.

Access Registrar, AccessPath, Any to Any, Are You Ready, AtmDirector, Browse with Me, CCDA, CCDE, CCDP, CCIE, CCNA, CCNP, CCSI, CD-PAC, the Cisco logo, Cisco Certified Internetwork Expert logo, *CiscoLink*, the Cisco Management Connection logo, the Cisco NetWorks logo, the Cisco Powered Network logo, Cisco Systems Capital, the Cisco Systems Capital logo, Cisco Systems Networking Academy, the Cisco Systems Networking Academy logo, the Cisco Technologies logo, Fast Step, FireRunner, Follow Me Browsing, FormShare, GigaStack, IGX, Intelligence in the Optical Core, Internet Quotient, IP/VC, IQ Breakthrough, IQ Expertise, IQ FastTrack, IQ Readiness Scorecard, The IQ Logo, Kernel Proxy, MGX, Natural Network Viewer, NetSonar, Network Registrar, the Networkers logo, *Packet*, PIX, Point and Click Internetworking, Policy Builder, Precept, RateMUX, ReyMaster, ReyView, ScriptShare, Secure Script, Shop with Me, SlideCast, SMARTnet, SVX, *The Cell*, TrafficDirector, TransPath, VlanDirector, Voice LAN, Wavelength Router, Workgroup Director, and Workgroup Stack are trademarks; Changing the Way We Work, Live, Play, and Learn, Empowering the Internet Generation, The Internet Economy, and The New Internet Economy are service marks; and Aironet, ASIST, BPX, Catalyst, Cisco, Cisco IOS, the Cisco IOS logo, Cisco Systems, the Cisco Systems logo, the Cisco Systems Cisco Press logo, CollisionFree, Enterprise/Solver, EtherChannel, EtherSwitch, FastHub, FastLink, FastPAD, FastSwitch, GeoTel, IOS, IP/TV, IPX, LightStream, LightSwitch, MICA, NetRanger, Post-Routing, Pre-Routing, Registrar, StrataView Plus, Stratm, TeleRouter, and VCO are registered trademarks of Cisco Systems, Inc. or its affiliates in the U.S. and certain other countries. All other trademarks mentioned in this document are the property of their respective owners. The use of the word partner does not imply a partnership relationship between Cisco and any other company. (0005R)

Copyright © 2000, Cisco Systems, Inc.  
All rights reserved.

